

# Neles™ Top-guided globe valve

## Series GU

Neles™ series GU globe valves are top-guided, single seat and contoured trim providing superior control performance and high reliability in wide range of applications. Standard units are equipped with Neles diaphragm actuators and valve controllers for precise flow control, extended operation life and performance monitoring online.

### Construction

- Compact and lightweight construction
- Wide variety of trims with different Cv and characteristics
- Both metal and soft seats are available depending on the application
- Optional bellows seal for toxic or other applications where no stem seal leakage is allowed
- Wide material selection for different applications
- Many end connection styles available for different applications
- Extension bonnet design for wide temperature range

### Accurate control

- Neles digital valve controller for auto-calibration and accurate control
- Accurate and sensitive diaphragm and piston actuators

### Wide range of applications

- Suitable for gas, liquid and steam
- Temperature limits -29 ... +425 °C / (-20 ... +797 °F) with standard bonnet construction and over +425 °C (+797 °F) and under -29 °C / (-20 °F) with extended bonnets
- Tendril™ multi-hole trim for high pressure drop and cavitation applications
- Micro trim for small flow and/or to get rid of the stability problems in high pressure drop application
- Inherently characterized trims offered in equal percentage, linear and quick open



### Safety and quality

- Rugged one piece body to minimize the leak paths and makes the valve less prone to pipe stress
- Strictly tested to ensure specified performance with quality assurance systems in accordance to ISO 9001
- Certified ISO 15848 fugitive emissions
- Certified CE/PED & ATEX, TSG & EAC (GOST-R)
- Certified SIL(Safety Integrity Level) in accordance to IEC61508

### Easy maintenance

- Quick change trim and top entry construction for easy in-line maintenance
- Self guiding components for easy valve assembly
- Flow characteristics can be easily changed with interchangeable trim components
- Neles digital valve controller with online diagnostics enables performance follow up and predictive maintenance
- Efficient asset management with any FDT frame application and excellent networking capabilities

## Different trim designs

### Contoured trim

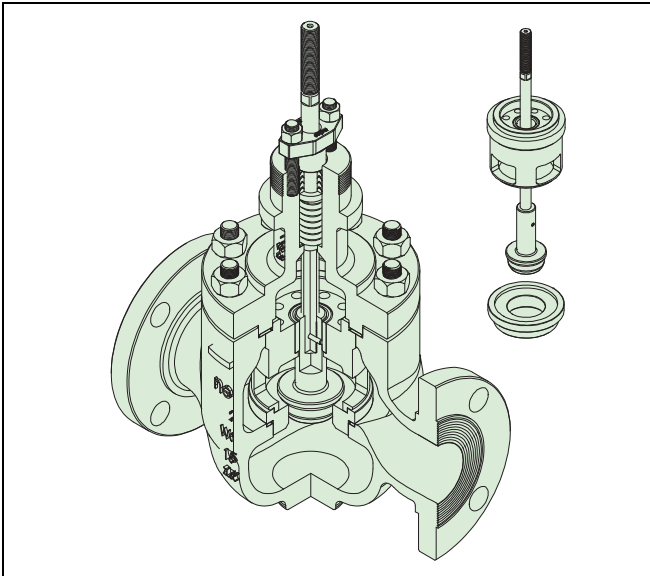

Quick change, general contoured trim  
Quick change, general contoured plug offers a smooth flow profile. The trim is most suited to low pressure drop application and is used in the majority of control applications.

### Tendril (multi-hole) trim

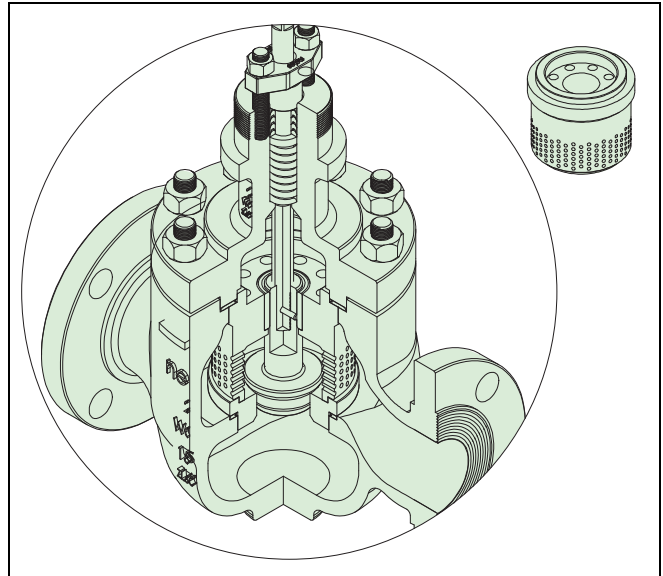

Tendril trim  
Tendril is a multi-hole trim where the flow is divided through multiple holes in which pressure progressively reduces while passing through the trim. This gives excellent resistance to cavitation and reduces noise in high pressure drop applications.

### Contoured soft seat trim

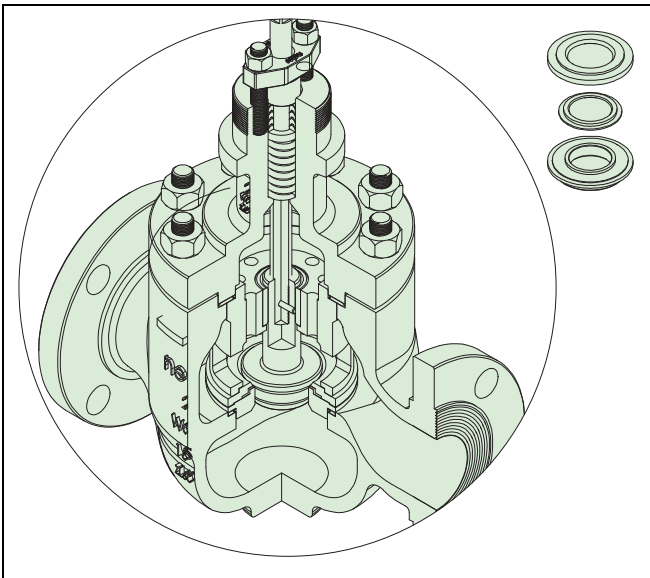

Soft seat trim  
An alteration of the standard contoured trim is the soft seated option. The seat ring is manufactured with a clamped on shroud which locks the soft seated ring in position. When the soft face contacts the seating point it deforms the softer ring ensuring a high degree of closure. The soft seated trim is used on applications where bubble tight shut off is required.

### Micro trim

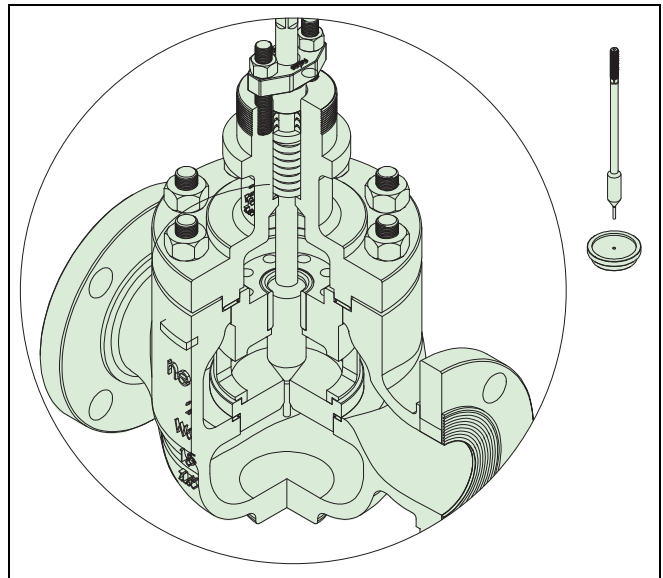

Micro trim  
The micro trim design is seat guided construction, capable of handling high pressure drops, without instability problems. This trim design has an inherent characteristic of linear, and has excellent rangeability. It is an ideal selection for the control of very low flow rates. Please contact Valmet for micro trim applications.

## Components & materials

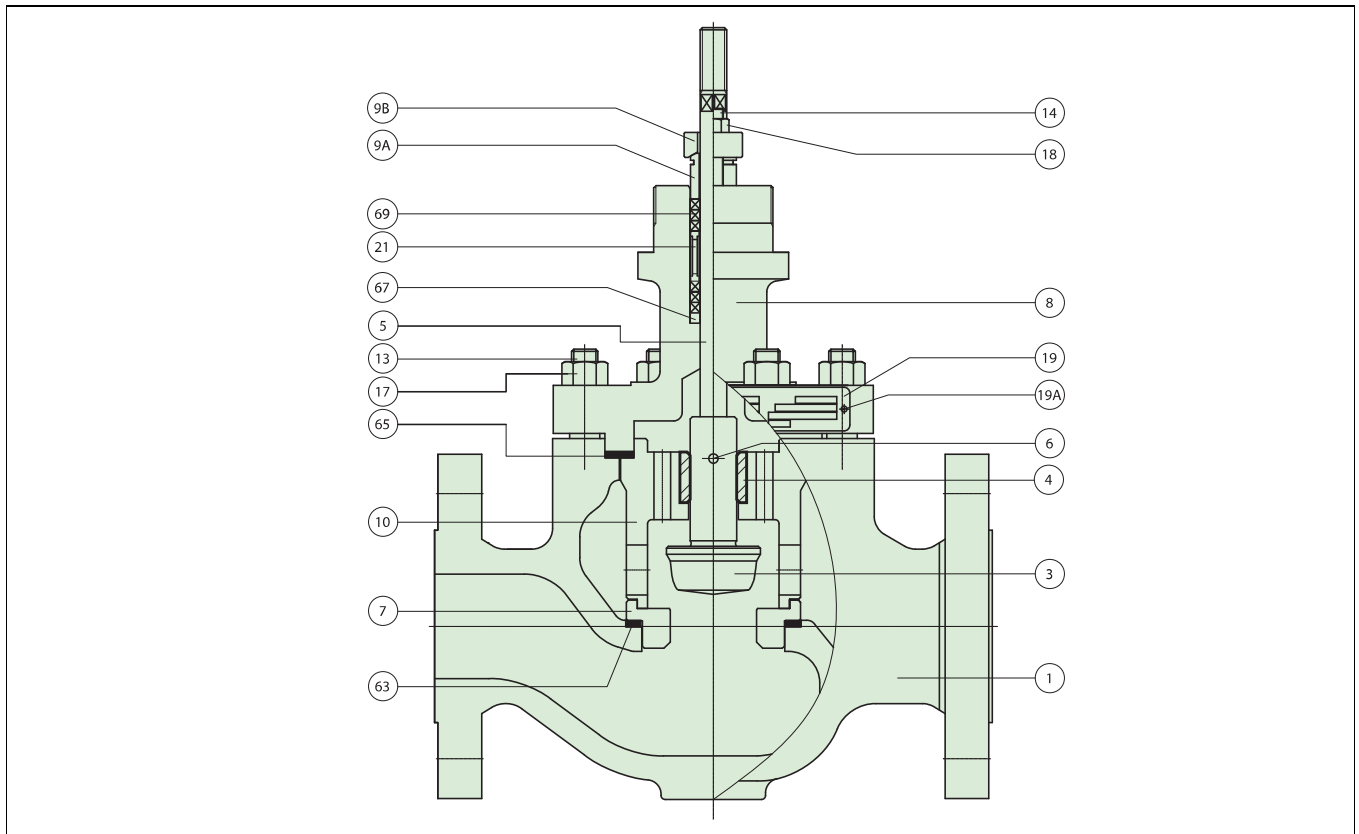

### Body material: Carbon steel or alloy steel

Part no.	Description	Material
1	BODY	ASTM A216 GR WCB
2	PLUG SET	410 SS / 630 SS
3*	PLUG	410 STAINLESS STEEL
4	GUIDE BUSHING	440C STAINLESS STEEL
5*	STEM	630 STAINLESS STEEL + HCr
6*	PLUG PIN	316 STAINLESS STEEL
7	SEAT RING	410 STAINLESS STEEL
8	BONNET	ASTM A216 GR WCB
9A	GLAND	304 STAINLESS STEEL
9B	GLAND FLANGE	A351 CF8
10	RETAINER	630 STAINLESS STEEL
13	STUD	A193 Gr.B7 M
14	STUD	A193 Gr.B8M
17	HEXAGON NUT	A194 Gr.2HM
18	HEXAGON NUT	A194 Gr.8M
19	IDENTIFICATION PLATE	304 STAINLESS STEEL
19A	RIVET	304 STAINLESS STEEL
21	LANTERN RING	304 STAINLESS STEEL
63	SEAT GASKET	S/W GASKET, 316L SS + GRAPHITE
65	BODY GASKET	S/W GASKET, 316L SS + GRAPHITE
67	PACKING SPACER	304 STAINLESS STEEL
69	PACKING RING	PTFE + CARBON FIBER

**Note.**

1. Plug/Seat hard facing (Cobalt based alloy) & Soft seat are available
2. Materials description  
316 SS : ASTM A276 gr. 316 or JIS 316 stainless steel  
440C SS : ASTM A276 gr.440C or JIS 440C stainless steel  
410 SS : ASTM A276 gr. 410 or JIS 410 stainless steel  
630 SS : ASTM A564 630 (H1100) or JIS 630 (H1100) St. Steel
3. Above standard materials to be applicable depending on specific service conditions. Other optional materials to consult Valmet
4. Optional materials to meet to requirements of NACE MR 01-75 are available
5. The materials are subject to change as equivalent depending on detail design
6. The part no. 3\*, 5\*, 6\* are delivered as a set with part no. 2
7. The identification plate is attached to the body when only the bare stem valve is required. And the identification plate is attached to the actuator yoke when the completed valve and actuator is delivered

### Body material: Stainless steel

Material	Spare
ASTM A351 GR CF8M	
316 SS / 316 SS	Cat 3
316 STAINLESS STEEL	Cat 3
316 + COBALT BASED ALLOY	
316 STAINLESS STEEL + HCr	Cat 3
316 STAINLESS STEEL	Cat 3
316 STAINLESS STEEL	Cat 3
ASTM A351 GR CF8M	
304 STAINLESS STEEL	
A351 CF8	
A351 CF8M	Cat 3
A193 Gr. B8M	
A193 Gr. B8M	
A194 Gr. 8M	
A194 Gr. 8M	
304 STAINLESS STEEL	
304 STAINLESS STEEL	
304 STAINLESS STEEL	
S/W GASKET, 316L SS + GRAPHITE	Cat 1
S/W GASKET, 316L SS + GRAPHITE	Cat 1
304 STAINLESS STEEL	
PTFE + CARBON FIBER	Cat 1

**Note.**

1. Plug/Seat hard facing (Cobalt based alloy) & Soft seat are available
2. Materials description  
316 SS : ASTM A276 gr. 316 or JIS 316 stainless steel
3. Above standard materials to be applicable depending on specific service conditions. Other optional materials to consult Valmet
4. Cryogenic application: ASTM A320 B8M & 8M for studs(13) and nuts(17)
5. Optional materials to meet to requirements of NACE MR 01-75 are available
6. The materials are subject to change as equivalent depending on detail design
7. The part no. 3\*, 5\*, 6\* are delivered as a set with part no. 2
8. The identification plate is attached to the body when only the bare stem valve is required. And the identification plate is attached to the actuator yoke when the completed valve and actuator is delivered.

## GU, Application guide

### GU, Temperature range and seat leakage class with different bonnet and seat application

Valve size DN / Inch	ASME rating	Seat type	Temperature range (°C)		Seat leakage class (ANSI B 16.104)	
			General bonnet	Extension bonnet	Standard	Optional
15/0.5... 150/6	150... 600	Metal Soft	-29...+425	-109...+593	IV VI	V
15 / 1/2... 80/3	900... 2500	Metal	-29...+425	-109...+593	IV	V

### Temperature range with different body and stud/ nut materials

Body, bonnet material	Stud bolt, nut material	Temp. range, (°C)	Sign
Carbon steel (WCB, A105)	ASTM A193-B7M STUD / ASTM A194-2HM NUT	-29...+425	G
Cr-Mo steel(WC6, WC9)	A193 gr. B16 STUD A194 gr. 7 NUT	-29...+593	H
Stainless steel (CF3, CF8,CF3M, CF8M)	ASTM A193-B8M / ASTM A194 -8M NUT	-196...+425	D

## Trim materials

GU, Trim				Temperature range (°C)	Sign
Plug	Stem	Seat	Retainer		
410 SS	630 SS + HCr	410 SS	630 SS	-29...+425	P1XBCS1R1X
316 SS	316 SS + HCr	316 SS	316 SS	-196...+425	T6XTCS1T6X
316 SS + Cobalt based alloy	316 SS + HCr	316 SS + Cobalt based alloy	316 SS	-196...+425	T6ATCS1T6A
316SS + Full cobalt based alloy	316SS + HCr	316SS + Full cobalt based alloy	CF8M / 316SS	-196...+425	T6ATCS1T6A.....E (Sign 19)
316SS + Full cobalt based alloy (both plug & plug guide)	XM-19	316SS + Full cobalt based alloy	CF8M / 316SS	-196...+593	T6ATCS1T6A.....H (sign 19)
420 J2	XM-19	420 J2	420 J2	-10...+540	P2XVXS1P2X
316 SS	316 SS + HCr	316 SS + PTFE	316 SS	-49...+232	*
Inconel 718	XM-19	F91	F91	-29...+593	*
Inconel 625, 718, 750				-196...+593	*

\*Please contact Valmet

### Gasket applications

Body, bonnet material	Gasket material	Temp. range (°C)	Sign
Carbon steel WCB, A105	S/W (Spiral wound) 316L SS + Graphite	-29...+425	S
Stainless steel CF8, CF8M, CF3, CF3M	S/W (Spiral wound) 316L SS + Graphite	-56...+425	S
	S/W (Spiral wound) 316L SS + PTFE	-196...+232	L
Cr.Mo. Steel WC6, WC9, F22, C12A, F91	S/W (Spiral wound)316L SS + High Graphite	-29...+593	H

Please contact Valmet

### Flow direction

Fluid media	Flow to open	Flow to close
Liquid	o	*
Steam Gas	o	*

\*Please contact Valmet

### Cv ratio

50: 1

### Flow characteristics

Equal percentage, linear and quick open

### Packing applications

Packing material	Temp (°C)	Pressure class	Sign
PTFE + Carbon Fiber (Braided TEF + Graphite), standard	-196...+260	Up to CL900	G
PTFE V-Ring	- 49...+232	Up to CL600	T
Graphite (with Mold + Braided)	-56...+400	Up to CL2500	F*
Hi-Graphite (with Mold + Braided)	-56...+593	Up to CL2500	H

\*Graphite packing with low emission, live loaded construction can be applicable up to +450 °C

## GU, Ratings & end connetions

Valve size DN / Inch"	GU, ASME ratings							
	Class 150 - 600				Class 900 - 2500			
	RF	RTJ	SW	BW	RF	RTJ	SW	BW
25 / 1	O	O	O		O	O	O	
40 / 1-1/2	O	O	O		O	O	O	
50 / 2	O	O	O		O	O	O	O
80 / 3	O	O		O				
100 / 4	O	O		O				

Note1. RF:Raised Face, RTJ: Ring Joint, SW:Socket Weld, BW: Butt Weld

## Packing constructions

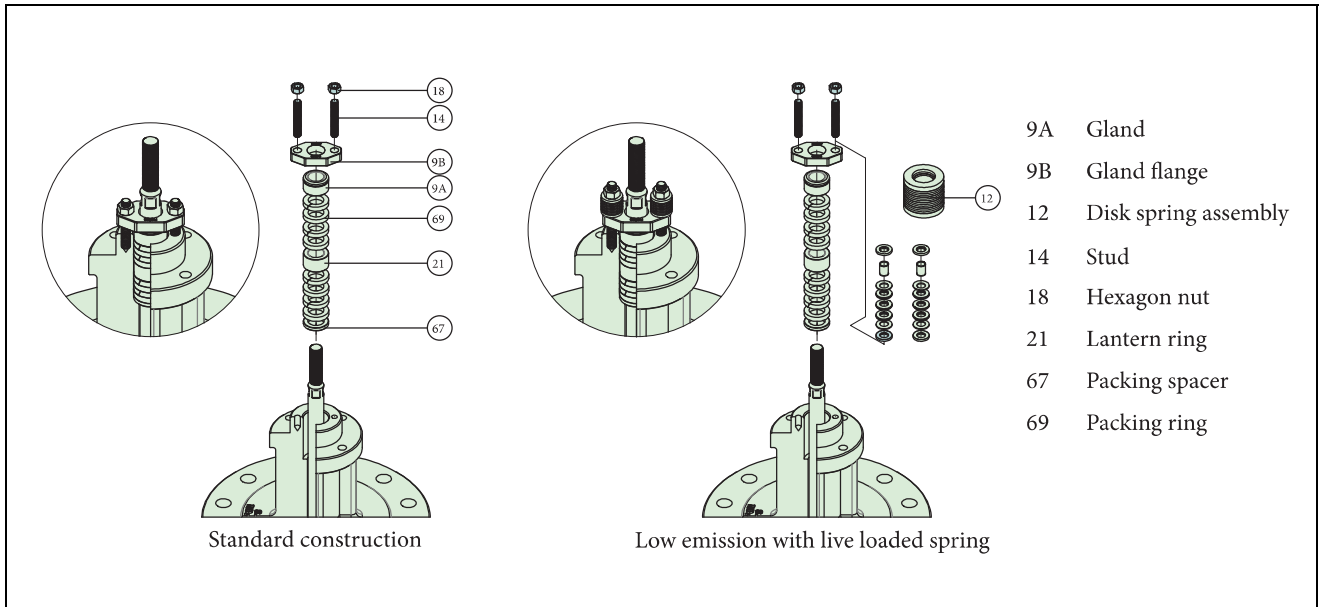

## Rated Cv and trim table (Globe single seat, unbalanced type, series GU)

20. Sign	Trim type	21. Sign	Trim characteristic	22. Sign	Description	Rated Cv																	
						Body size and stroke																	
						0.5"	Str.	0.75"	Str.	1"	Str.	1.5"	Str.	2"	Str.	3"	Str.	4"	Str.	6"	Str.		
A	General plug	L	Linear	FC	General / Full capacity	7	(20)	9	(20)	13.5	(20)	28	(20)	49	(20)	100	(40)	190	(40)	295	(60)		
					E	Equal %	1A General / 1-Step reduction	4	(20)	5.5	(20)	8.5	(20)	16	(20)	28	(20)	70	(40)	120	(40)	165	(60)
							2A General / 2-Step reduction	2.3	(20)	3	(20)	5.4	(20)	10.5	(20)	17	(20)	42	(40)	72	(40)	85	(60)
							3A General / 3-Step reduction	1.5	(20)	2	(20)	3.1	(20)	6	(20)	10	(20)	25	(40)	42	(40)	50	(60)
							4A General / 4-Step reduction	0.8	(20)	1.2	(20)	2	(20)	4	(20)								
							5A General / 5-Step reduction	0.5	(20)	0.7	(20)	1.2	(20)	2.2	(20)								
							6A General / 6-Step reduction	0.3	(20)	0.4	(20)	0.8	(20)	1.2	(20)								
		FT Tendril / Full capacity	7	(20)	9	(20)	13.5	(20)	28	(20)	49	(20)	100	(40)	190	(40)	IQI	(60)					
		L	Linear	FC	General / Full capacity	0.1	(20)	0.1	(20)	0.1	(20)												
					1A General / 1-Step reduction	0.06	(20)	0.06	(20)	0.06	(20)												
					2A General / 2-Step reduction	0.03	(20)	0.03	(20)	0.03	(20)												
					3A General / 3-Step reduction	0.01	(20)	0.01	(20)	0.01	(20)												
					4A General / 4-Step reduction	0.006	(20)	0.006	(20)	0.006	(20)												
					5A General / 5-Step reduction	0.003	(20)	0.003	(20)	0.003	(20)												
YY Special	YY				Special	Please contact sales office for more information																	

- Rated Cv is different depending on trim type and characteristic.  
 - Str. : valve stroke length (mm). It should be matched with actuator stroke length.

**GU Series Cv vs Travel (General contoured)**  
**ANSI Class: 150# - 1500**

Size: 1/2" - 6"

Flow characteristic: linear

Valve travel [%]							10	20	30	40	50	60	70	80	90	100				
F <sub>L</sub>							0.93	0.93	0.92	0.92	0.91	0.91	0.91	0.90	0.90	0.90	0.90			
Valve size		Orifice diameter			Travel		Rated Cv													
Inch	mm	Sign	Inch	mm	Inch	mm														
1/2"	15	FC	0.6	15.7	0.8	20	0.53	1.27	1.95	2.66	3.38	4.09	4.76	5.51	6.67	7.0				
		1A	0.4	11.0			0.36	0.74	1.23	1.61	1.99	2.37	2.72	3.05	3.41	4.0				
		2A	0.3	8.0			0.28	0.53	0.79	1.07	1.32	1.52	1.71	1.88	2.03	2.3				
		3A	0.3	6.4			0.19	0.36	0.52	0.67	0.82	0.97	1.15	1.28	1.38	1.5				
		4A	0.3	6.4			0.09	0.17	0.25	0.32	0.40	0.47	0.54	0.61	0.68	0.8				
		5A	0.3	6.4			0.06	0.11	0.15	0.20	0.25	0.30	0.35	0.40	0.45	0.5				
3/4"	20	FC	0.7	17.2	0.8	20	0.85	1.68	2.57	3.31	4.04	4.74	5.43	6.18	7.61	9.0				
		1A	0.5	13.0			0.35	0.82	1.40	2.17	2.78	3.39	3.98	4.53	5.03	5.5				
		2A	0.4	9.0			0.29	0.74	1.08	1.40	1.73	2.13	2.37	2.60	2.80	3.0				
		3A	0.3	7.2			0.24	0.44	0.63	0.81	0.99	1.16	1.32	1.47	1.62	2.0				
		4A	0.3	6.4			0.13	0.24	0.36	0.48	0.60	0.72	0.84	0.96	1.08	1.2				
		5A	0.3	6.4			0.08	0.15	0.22	0.28	0.35	0.42	0.49	0.56	0.63	0.7				
1"	25	FC	0.9	22.3	0.8	20	1.29	2.62	4.02	5.42	6.83	8.13	8.90	10.25	11.93	13.5				
		1A	0.6	15.0			0.77	1.54	2.31	3.15	3.92	4.68	5.42	6.12	7.00	8.5				
		2A	0.5	11.5			0.46	0.94	1.43	1.94	2.46	3.02	3.52	4.00	4.44	5.4				
		3A	0.4	9.0			0.28	0.56	0.86	1.16	1.47	1.77	2.07	2.36	2.66	3.1				
		4A	0.3	7.2			0.18	0.37	0.57	0.78	0.99	1.20	1.41	1.61	1.79	2.0				
		5A	0.3	6.4			0.11	0.23	0.35	0.47	0.59	0.71	0.83	0.95	1.07	1.2				
1-1/2"	40	FC	1.2	30.0	0.8	20	2.64	5.38	8.46	11.77	15.22	18.77	21.56	24.09	26.50	28.0				
		1A	0.8	21.5			1.63	3.16	4.70	6.25	7.90	9.52	11.12	12.68	14.18	16.0				
		2A	0.6	16.0			0.95	1.89	2.86	3.86	4.88	5.88	6.90	7.92	8.86	10.5				
		3A	0.5	12.5			0.57	1.13	1.72	2.33	2.96	3.58	4.19	4.78	5.33	6.0				
		4A	0.4	10.0			0.37	0.74	1.14	1.54	1.96	2.38	2.79	3.18	3.55	4.0				
		5A	0.3	7.0			0.19	0.38	0.57	0.78	0.99	1.19	1.40	1.60	1.78	2.2				
2"	50	FC	1.7	43.9	0.8	20	4.13	9.24	14.48	19.71	25.09	30.56	35.97	40.01	44.64	49.0				
		1A	1.3	33.4			2.27	4.97	7.88	10.94	13.72	16.51	19.28	22.03	24.97	28.0				
		2A	0.8	21.5			1.26	2.76	4.37	6.05	7.77	9.53	11.23	12.73	14.32	17.0				
		3A	0.6	16.0			0.82	1.78	2.80	3.86	4.93	5.98	7.01	7.98	8.89	10.0				
		3"	80	FC			2.8	72.0	1.5	40	9.96	21.06	32.40	42.65	52.98	63.70	76.67	86.07	91.15	100.0
				1A			1.9	47.0			5.35	11.64	18.74	26.58	33.66	40.46	47.18	53.74	60.34	70.0
2A	1.3			34.0	3.47	7.21	11.20	15.38			19.69	24.06	28.45	31.99	35.66	42.0				
3A	1.0			25.0	2.17	4.47	6.86	9.32			11.81	14.29	16.73	19.08	21.29	25.0				
4"	100			FC	3.6	91.5	1.5	40			12.67	27.12	47.27	66.04	85.99	106.88	127.85	147.47	167.93	190.0
				1A	2.4	60.0					7.32	15.77	25.33	36.43	51.05	63.30	75.78	88.32	103.94	120.0
		2A	1.7	43.0	7.02	13.84			20.64	27.41	34.07	43.44	50.85	57.09	63.09	72.0				
		3A	1.3	32.0	4.03	8.16			12.45	16.82	21.18	25.44	29.51	33.31	37.67	42.0				
		6"	150	FC	4.5	115.0			2.4	60	28.43	57.15	86.05	112.26	136.07	159.16	181.59	212.57	263.12	295.0
				1A	3.0	75.0					16.09	32.01	47.67	63.09	78.18	93.11	105.76	117.42	137.91	165.0
2A	1.8			46.5	8.78	17.43	25.90	34.15			42.13	49.78	57.07	63.94	71.49	85.0				
3A	1.4			35.5	4.32	9.07	14.14	19.45			24.88	30.32	35.64	40.72	45.42	50.0				

**ANSI Class: 150# - 1500#**

Size: 1/2" - 6"

Flow characteristic: EQ%

Valve Travel [%]		10	20	30	40	50	60	70	80	90	100									
F <sub>L</sub>		0.93	0.93	0.93	0.93	0.93	0.92	0.92	0.91	0.91	0.90									
Valve size		Orifice diameter			Travel		Rated Cv													
Inch	mm	Sign	Inch	mm	Inch	mm														
1/2"	15	FC	0.6	15.7	0.8	20	0.16	0.36	0.56	0.89	1.38	2.16	3.42	4.84	6.44	7.0				
		1A	0.4	11.0			0.06	0.16	0.31	0.49	0.78	1.46	2.17	2.88	3.53	4.0				
		2A	0.3	8.0			0.08	0.16	0.23	0.34	0.59	0.94	1.37	1.70	2.01	2.3				
		3A	0.3	6.4			0.05	0.09	0.14	0.20	0.35	0.56	0.82	1.11	1.33	1.5				
		4A	0.3	6.4			0.02	0.04	0.06	0.08	0.16	0.28	0.41	0.54	0.66	0.8				
		5A	0.3	6.4			0.01	0.02	0.04	0.05	0.10	0.17	0.25	0.33	0.41	0.5				
3/4"	20	FC	0.7	17.2	0.8	20	0.24	0.45	0.67	1.07	1.85	2.93	4.02	5.23	7.13	9.0				
		1A	0.5	13.0			0.06	0.20	0.40	0.67	1.11	1.79	2.79	3.71	4.74	5.5				
		2A	0.4	9.0			0.05	0.17	0.28	0.45	0.78	1.20	1.80	2.35	2.72	3.0				
		3A	0.3	7.2			0.04	0.09	0.15	0.21	0.41	0.68	1.00	1.30	1.67	2.0				
		4A	0.3	6.4			0.03	0.06	0.09	0.13	0.25	0.42	0.62	0.82	1.01	1.2				
		5A	0.3	6.4			0.01	0.03	0.05	0.08	0.14	0.23	0.34	0.45	0.58	0.7				
1"	25	FC	0.9	22.3	0.8	20	0.27	0.57	0.91	1.55	2.75	4.66	7.08	9.49	11.63	13.5				
		1A	0.6	15.0			0.12	0.29	0.51	0.83	1.56	2.70	4.14	5.61	7.03	8.5				
		2A	0.5	11.5			0.07	0.19	0.33	0.53	0.97	1.67	2.65	3.59	4.37	5.4				
		3A	0.4	9.0			0.03	0.09	0.19	0.32	0.58	1.00	1.52	2.05	2.54	3.1				
		4A	0.3	7.2			0.03	0.08	0.13	0.22	0.40	0.67	1.00	1.35	1.70	2.0				
		5A	0.3	6.4			0.03	0.05	0.08	0.13	0.25	0.43	0.64	0.85	1.06	1.2				
1-1/2"	40	FC	1.2	30.0	0.8	20	0.45	1.12	2.00	3.07	5.91	10.57	16.18	21.57	25.66	28.0				
		1A	0.8	21.5			0.23	0.58	1.06	1.69	3.16	5.36	7.97	10.69	13.44	16.0				
		2A	0.6	16.0			0.20	0.44	0.71	1.02	1.88	3.25	4.93	6.71	8.59	10.5				
		3A	0.5	12.5			0.09	0.22	0.40	0.62	1.13	2.02	3.17	4.26	5.21	6.0				
		4A	0.4	10.0			0.05	0.14	0.26	0.41	0.79	1.36	2.08	2.83	3.45	4.0				
		5A	0.3	7.0			0.03	0.08	0.13	0.21	0.39	0.69	1.07	1.43	1.74	2.2				
2"	50	FC	1.7	43.9	0.8	20	1.21	2.46	3.31	5.12	9.42	16.83	26.55	36.59	44.52	49.0				
		1A	1.3	33.4			0.32	0.82	1.51	2.87	5.48	9.31	13.77	18.31	23.17	28.0				
		2A	0.8	21.5			0.17	0.47	0.88	1.63	3.18	5.47	8.21	11.09	13.68	17.0				
		3A	0.6	16.0			0.15	0.37	0.66	1.02	1.89	3.29	5.01	6.71	8.41	10.0				
		3"	80	FC			2.8	72.0	1.5	40	2.01	4.47	7.37	12.28	22.52	38.62	62.02	79.57	90.09	100.0
				1A			1.9	47.0			1.00	2.51	4.50	6.96	12.95	23.65	36.15	47.82	58.70	70.0
2A	1.3			34.0	0.73	1.61	2.64	3.95			7.53	13.57	21.26	28.97	34.99	42.0				
3A	1.0			25.0	0.36	0.89	1.59	2.46			4.51	8.08	12.55	16.82	20.78	25.0				
4"	100			FC	3.6	91.5	1.5	40			2.90	6.72	11.48	17.16	29.35	56.26	86.65	120.90	153.84	190.0
				1A	2.4	60.0					1.56	3.77	6.63	10.11	18.42	32.83	55.27	77.53	98.63	120.0
		2A	1.7	43.0	1.45	3.05			4.82	8.10	14.86	24.20	35.22	49.81	61.14	72.0				
		3A	1.3	32.0	0.88	1.82			2.84	4.44	8.42	14.38	21.12	27.79	34.17	42.0				
		6"	150	FC	4.5	115.0			2.4	60	4.23	9.72	16.43	25.73	49.58	89.69	140.01	195.77	256.78	295.0
				1A	3.0	75.0					2.83	6.73	11.68	17.72	31.53	53.90	88.37	113.11	140.55	165.0
2A	1.8			46.5	1.36	3.61	6.68	10.62			17.82	28.66	42.88	57.38	71.53	85.0				
3A	1.4			35.5	0.91	1.90	2.95	4.26			7.77	13.68	21.42	29.72	37.96	50.0				

**NOTE**

Cv: Valve flow coefficient

FL: Liquid pressure recovery factor

FC: Full capacity

1A: 1-Step reduction    2A: 2-Step reduction    3A: 3-Step reduction

4A: 4-Step reduction    5A: 5-Step reduction    6A: 6-Step reduction

**Contoured trim (with Tendril 1)**  
**ANSI Class: 150# - 1500#**

Size: 1/2" - 4"

Valve travel [%]							10	20	30	40	50	60	70	80	90	100
F <sub>L</sub>							0,95	0,95	0,95	0,94	0,94	0,94	0,93	0,93	0,91	0,91
Valve size		Orifice diameter			Travel		Rated Cv									
Inch	mm	Sign	Inch	mm	Inch	mm										
1/2"	15	FT	0.6	15.7	0.8	20	0.53	1.27	1.95	2.66	3.38	4.09	4.76	5.51	6.67	7.0
		1T	0.4	11.0			0.36	0.74	1.23	1.61	1.99	2.37	2.72	3.05	3.41	4.0
		2T	0.3	8.0			0.28	0.53	0.79	1.07	1.32	1.52	1.71	1.88	2.03	2.3
		3T	0.3	6.4			0.19	0.36	0.52	0.67	0.82	0.97	1.15	1.28	1.38	1.5
		4T	0.3	6.4			0.09	0.17	0.25	0.32	0.40	0.47	0.54	0.61	0.68	0.8
		5T	0.3	6.4			0.06	0.11	0.15	0.20	0.25	0.30	0.35	0.40	0.45	0.5
3/4"	20	FT	0.7	17.2	0.8	20	0.85	1.68	2.57	3.31	4.04	4.74	5.43	6.18	7.61	9.0
		1T	0.5	13.0			0.35	0.82	1.40	2.17	2.78	3.39	3.98	4.53	5.03	5.5
		2T	0.4	9.0			0.29	0.74	1.08	1.40	1.73	2.13	2.37	2.60	2.80	3.0
		3T	0.3	7.2			0.24	0.44	0.63	0.81	0.99	1.16	1.32	1.47	1.62	2.0
		4T	0.3	6.4			0.13	0.24	0.36	0.48	0.60	0.72	0.84	0.96	1.08	1.2
		5T	0.3	6.4			0.08	0.15	0.22	0.28	0.35	0.42	0.49	0.56	0.63	0.7
1"	25	FT	0.9	22.3	0.8	20	1.29	2.62	4.02	5.42	6.83	8.13	8.90	10.25	11.93	13.5
		1T	0.6	15.0			0.77	1.54	2.31	3.15	3.92	4.68	5.42	6.12	7.00	8.5
		2T	0.5	11.5			0.46	0.94	1.43	1.94	2.46	3.02	3.52	4.00	4.44	5.4
		3T	0.4	9.0			0.28	0.56	0.86	1.16	1.47	1.77	2.07	2.36	2.66	3.1
		4T	0.3	7.2			0.18	0.37	0.57	0.78	0.99	1.20	1.41	1.61	1.79	2.0
		5T	0.3	6.4			0.11	0.23	0.35	0.47	0.59	0.71	0.83	0.95	1.07	1.2
1-1/2"	40	FT	1.2	30.0	0.8	20	2.64	5.38	8.46	11.77	15.22	18.77	21.56	24.09	26.50	28.0
		1T	0.8	21.5			1.63	3.16	4.70	6.25	7.90	9.52	11.12	12.68	14.18	16.0
		2T	0.6	16.0			0.95	1.89	2.86	3.86	4.88	5.88	6.90	7.92	8.86	10.5
		3T	0.5	12.5			0.57	1.13	1.72	2.33	2.96	3.58	4.19	4.78	5.33	6.0
		4T	0.4	10.0			0.37	0.74	1.14	1.54	1.96	2.38	2.79	3.18	3.55	4.0
		5T	0.3	7.0			0.19	0.38	0.57	0.78	0.99	1.19	1.40	1.60	1.78	2.2
2"	50	FT	1.7	43.9	0.8	20	4.13	9.24	14.48	19.71	25.09	30.56	35.97	40.01	44.64	49.0
		1T	1.3	33.4			2.27	4.97	7.88	10.94	13.72	16.51	19.28	22.03	24.97	28.0
		2T	0.8	21.5			1.26	2.76	4.37	6.05	7.77	9.53	11.23	12.73	14.32	17.0
		3T	0.6	16.0			0.82	1.78	2.80	3.86	4.93	5.98	7.01	7.98	8.89	10.0
3"	80	FT	2.8	72.0	1.5	40	9.96	21.06	32.40	42.65	52.98	63.70	76.67	86.07	91.15	100.0
		1T	1.9	47.0			5.35	11.64	18.74	26.58	33.66	40.46	47.18	53.74	60.34	70.0
		2T	1.3	34.0			3.47	7.21	11.20	15.38	19.69	24.06	28.45	31.99	35.66	42.0
4"	100	FT	3.6	91.5	1.5	40	12.67	27.12	47.27	66.04	85.99	106.88	127.85	147.47	167.93	190.0
		1T	2.4	60.0			7.32	15.77	25.33	36.43	51.05	63.30	75.78	88.32	103.94	120.0
		2T	1.7	43.0			7.02	13.84	20.64	27.41	34.07	43.44	50.85	57.09	63.09	72.0
		3T	1.3	32.0			4.03	8.16	12.45	16.82	21.18	25.44	29.51	33.31	37.67	42.0

**NOTE**

Cv: Valve flow coefficient

FL: Liquid pressure recovery factor

FC: Full capacity

1A: 1-Step reduction

2A: 2-Step reduction

3A: 3-Step reduction

4A: 4-Step reduction

5A: 5-Step reduction

6A: 6-Step reduction

## GU, Valve dimensions and weights

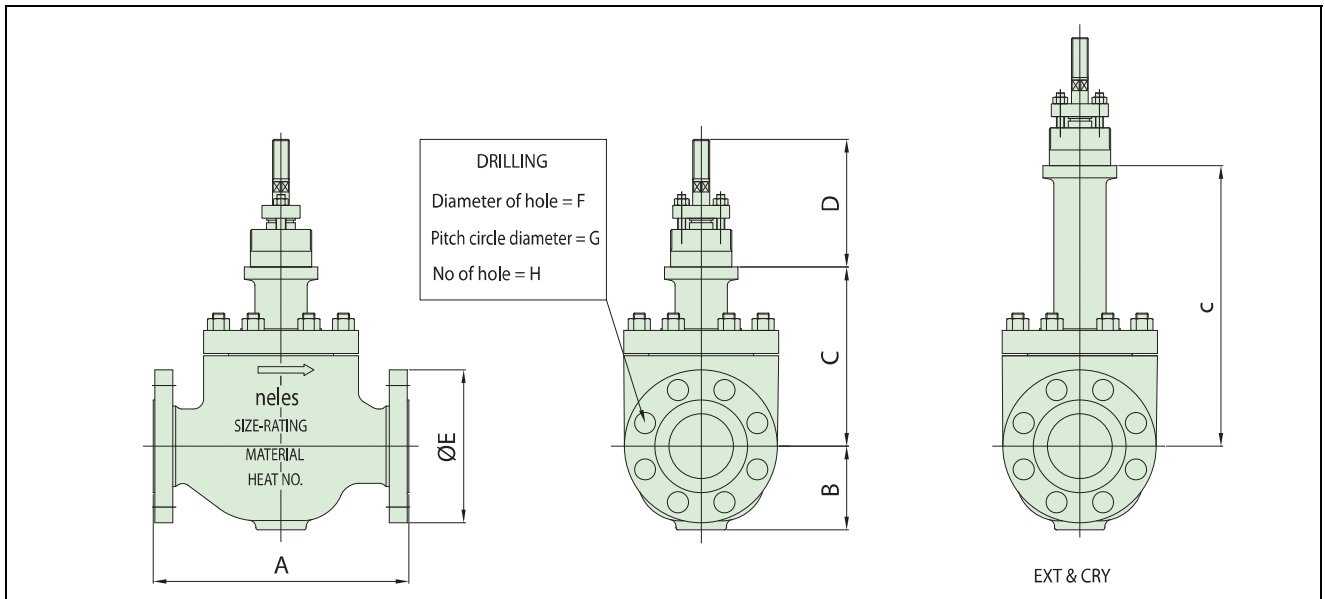

### 150 #/ 300 #/ 600 #

Dimension (mm)	A			B			C			D	E			F			G			H			Weight (kg) (Approximate)		
	150#	300#	600#	150#	300#	600#	STD	EXT	CRY	COMMON	150#	300#	600#	150#	300#	600#	150#	300#	600#	150#	300#	600#	150#	300#	600#
15	184	190	203	44.5	47.5	47.5	142	250	400	110	90	95	95	15.9	15.9	15.9	60.3	66.7	66.7	4	4	4	14	15	23
20	184	194	206	49	57.5	57.5	142	250	400	110	100	115	115	15.9	19.1	19.1	69.9	82.6	82.6	4	4	4	14	15	23
25	184	197	210	55	63	63	142	250	400	110	110	125	125	15.9	19.1	19.1	79.4	88.9	88.9	4	4	4	14	15	23
40	222	235	251	65	78	78	161	269	419	110	125	155	155	15.9	22.2	22.2	98.4	114.3	114.3	4	4	4	22	23	32
50	254	267	286	83	83	83	178	333	458	110	150	165	165	19.1	19.1	19.1	120.7	127	127	4	8	8	25	27	32
80	298	318	337	109	109	120	222	395	545	115	190	210	210	19.1	22.2	22.2	152.4	168.3	168.3	4	8	8	55	57	62
100	352	368	394	135	135	135	248	402	552	140	230	255	275	19.1	22.2	25.4	190.5	200	215.9	8	8	8	80	83	92

Dimension (inch)	A			B			C			D	E			F			G			H			Weight (lbs) (Approximate)		
	150#	300#	600#	150#	300#	600#	STD	EXT	CRY	COMMON	150#	300#	600#	150#	300#	600#	150#	300#	600#	150#	300#	600#	150#	300#	600#
1/2"	7.24	7.48	7.99	1.75	1.87	1.87	5.59	9.84	15.74	4.33	3.54	3.74	3.74	0.63	0.63	0.63	2.37	2.63	2.63	4	4	4	31	33	51
3/4"	7.24	7.64	8.11	1.93	2.26	2.26	5.59	9.84	15.74	4.33	3.94	4.53	4.53	0.63	0.75	0.75	2.75	3.25	3.25	4	4	4	31	33	51
1"	7.24	7.76	8.27	2.17	2.48	2.48	5.59	9.84	15.74	4.33	4.33	4.92	4.92	0.63	0.75	0.75	3.13	3.5	3.5	4	4	4	31	33	51
1-1/2"	8.74	9.25	9.88	2.56	3.07	3.07	6.34	10.59	16.49	4.33	4.92	6.1	6.1	0.63	0.87	0.87	3.87	4.5	4.5	4	4	4	49	51	60
2"	10	10.51	11.26	3.27	3.27	3.27	7.01	13.11	18.03	4.33	5.91	6.5	6.5	0.75	0.75	0.75	4.75	5	5	4	8	8	55	60	71
3"	11.73	12.52	13.27	4.29	4.29	4.72	8.74	15.55	21.45	4.53	7.48	8.27	8.27	0.75	0.87	0.87	6	6.63	6.63	4	8	8	121	126	137
4"	13.86	14.49	15.51	5.31	5.31	5.31	9.76	15.82	21.73	5.51	9.06	10.04	10.83	0.75	0.87	1	7.5	7.87	8.5	8	8	8	176	183	203

P.C.D = Pitch Circle Diameter

### 900 #/ 1500 #

Dimension (mm)	A		B		C		D	E		F		G		H		Weight (kg) (Approximate)	
	900#	1500#	900#	1500#	STD	EXT	COMMON	900#	1500#	900#	1500#	900#	1500#	900#	1500#	900#	1500#
15	292	292	78	78	236	330	150	120	120	22.2	22.2	82.6	82.6	4	4	60	60
20	292	292	78	78	236	330	150	130	130	22.2	22.2	88.9	88.9	4	4	60	60
25	292	292	82	82	236	330	150	150	150	25.4	25.4	101.6	101.6	4	4	60	60
40	333	333	100	100	240	380	150	180	180	28.5	28.5	123.8	123.8	4	4	63	63
50	375	375	113	113	240	380	225	215	215	25.4	25.4	165.1	165.1	8	8	67	67
80	441	460	142	142	322	430	225	240	265	25.4	31.7	190.5	203.2	8	8	150	163

Dimension (inch)	A		B		C		D	E		F		G		H		Weight (lbs) (Approximate)	
	900#	1500#	900#	1500#	STD	EXT	COMMON	900#	1500#	900#	1500#	900#	1500#	900#	1500#	900#	1500#
1/2"	11.5	11.5	3.07	3.07	9.29	13	5.9	4.72	4.72	0.87	0.87	3.25	3.25	4	4	132	132
3/4"	11.5	11.5	3.07	3.07	9.29	13	5.9	5.12	5.12	0.87	0.87	3.5	3.5	4	4	132	132
1"	11.5	11.5	3.23	3.23	9.29	13	5.9	5.91	5.91	1	1	4	4	4	4	132	132
1-1/2"	13.11	13.11	3.94	3.94	9.45	15	5.9	7.09	7.09	1.12	1.12	4.87	4.87	4	4	139	139
2"	14.76	14.76	4.45	4.45	9.45	15	8.86	8.46	8.46	1	1	6.5	6.5	8	8	148	148
3"	17.36	18.11	5.59	5.59	13.19	17	8.86	9.45	10.43	1	1.25	7.5	8	8	8	331	359

NOTE

P.C.D = Pitch Circle Diameter

## How to order Globe unbalanced, top guided type, series GU

1.	2.	3.	4.	5.	6.	7.	8.	9.	10.	11.	12.	13.	14.	15.	16.	17.	18.	19.	20.	21.	22.
GU	01	C	W	A	J2	B	P1	X	BC	S1	R1	X	S	G	X	S	G	X	A	L	FC

### Valve constructions

1. Valve series			
GU	Globe unbalanced, topguided type		
2. Body size			
0H	0.5" / DN 15	3Q	0.75" / DN 20
01	1" / DN 25	1H	1-1/2" / DN 40
02	2" / DN 50	03	3" / DN 80
04	4" / DN 100		
Optional body size			
06	6" / DN 150	YY	Special
3. Pressure rating			
C	ASME class 150	D	ASME class 300
F	ASME class 600	G	ASME class 900
H	ASME class 1500	I	ASME Class 2500
J	EN PN 10	K	EN PN 16
L	EN PN 25	M	EN PN 40
N	EN PN 63	P	EN PN 100
B	EN PN 160	E	EN PN 250
Y	EN PN 320	R	JIS 10K
T	JIS 20K		
4. End connection			
W	Flanged RF, ASME B16.5		
C	Flanged RF, EN 1092-1		
V	Socket welding, ASME B16.11		
Q	Butt welding, ASME B16.25		
Optional end connection			
Z	Ring joint flange, ASME B16.5		
Y	Special		
5. Bonnet construction			
Bonnet type	Actuator connection		
A	General	Applicable for VD_25/29/37	
B	General	Applicable for VD_48/55	
C	General	Applicable for VC_30, VB_32	
E	Extension	Applicable for VD_25/29/37	
F	Extension	Applicable for VD_48/55	
G	Extension	Applicable for VC_30, VB_32	
P	Cryogenic	Applicable for VD_25/29/37	
Q	Cryogenic	Applicable for VD_48/55	
R	Cryogenic	Applicable for VC_30, VB_32	
Optional bonnet construction			
J	Bellows seals	Applicable for VD_25/29/37	
K	Bellows seals	Applicable for VD_48/55	
L	Bellows seals	Applicable for VC_30, VB_32	
Y	Special	Special	
6. Body material			
J2	A216 gr. WCB		
S6	A351 gr. CF8M		
J4	A217 gr. WC6		
CG	A217 gr. WC9		
Optional body material			
S1	A351 gr. CF3M		
YY	Special		
7. Model code			
B	Model B		

- Bonnet material is equivalent with body material.

### Trim constructions

8. Plug material			
Material	Description		
P1	410 SS	General for carbon steel valve	
T6	316 SS	General for stainless steel valve	
VM	Alloy 6	Use for small Cv and Micro plug	
P2	420J2	General for Cr-Mo valve	
Optional plug material			
S1	316L SS		
YY	Special	Special materials	
9. Plug application			
X	Not applicable		
A	Cobalt based alloy		
Optional plug material			
Y	Special		
10. Stem material			
Material	Description		
BC	630 SS + HCr	General for carbon steel valve	
TC	316 SS + HCr	General for stainless steel valve	
VX	XM-19	General for Cr-Mo valve	
Optional stem material			
FC	316L SS + HCr		
11. Seat type			
S1	Single metal seat		
T1	Single soft seat		
Optional seat type			
YY	Special		
12. Seat / retainer material			
Seat	Retainer	Guide bushing	
R1	CA15 / 410 SS	CB7Cu-1 / 630 SS	AISI 440C
T6	CF8M / 316 SS	CF8M / 316 SS	AISI 316 + Alloy 6
V6	Alloy 6	CF8M / 316 SS	AISI 316 + Alloy 6
P2	420J2	CA40/420J2	AISI 440C
Optional Seat / Retainer Material			
R2	420J2 SS	CB7Cu-1 / 630 SS	AISI 440C
R3	316 SS	316 SS	AISI 316 + Alloy 6
YY	Special	Special	Special
- AISI 410 is general for carbon steel valve.			
- AISI 316 is general for stainless steel valve.			
13. Seat application			
X	Not applicable		
A	Cobalt based alloy		
P	Insert PTFE		
Optional seat application			
Q	Insert PTFE + Cobalt based alloy		
Y	Special		
Others			
14. Packing / bellows type			
S	General packing		
E	Low emission, live loaded		
Optional packing / Bellows type			
C	Bellows Seal (316L SS, Formed)		
Y	Special		

15. Packing material	
G	PTFE + Carbon fiber
F	Graphite
T	PTFE V-Ring
C	PTFE + Carbon fiber (ATEX)
H	Hi-Graphite
Optional packing material	
Y	Special

16. Seal ring material	
X	Not applicable

17. Gasket material	
S	S/W gasket type, 316L SS + Graphite
L	S/W gasket type, 316L SS + PTFE
H	S/W gasket type, 316L SS + Hi-Graphite
Optional gasket material	
Y	Special

18. Stud / Nut material	
G	A193 gr. B7M / A194 gr. 2HM
D	A193 gr. B8M / A194 gr. 8M
K	A320 gr. B8M cl. 2 / A194 gr. 8M
H	A193 gr. B16 / A194 gr. 7
E	A453 gr. 660/ A453 gr. 660
Optional stud / Nut material	
Y	Special

19. Options	
X	Not applicable
E	Anti-erosion
H	Alloy 6 coating on plug & plug guide for High temp. (top-guided valve only)
Special options	
L	Lub. & Isol. valve
W	Water seal
Y	Special

- \* Face to face length according to ISA 75.08
- \* The body, bonnet, trim materials are subject to change as equivalent depending on detail design.
- \* Please see 'Neles Globe Typecode Instruction' for further options.

### Trim type & rated Cv

20. Sign	Trim type	21. Sign	Trim characteristic	22. Sign	Description	Rated Cv																
						Body size and stroke																
						1/2"	Str.	3/4"	Str.	1"	Str.	1-1/2"	Str.	2"	Str.	3"	Str.	4"	Str.	6"	Str.	
A	General plug type	L	Linear	FC	Full capacity	7	(20)	9	(20)	13.5	(20)	28	(20)	49	(20)	100	(40)	190	(40)	295	(60)	
			Equal %	1A	1-Step reduction	4	(20)	5.5	(20)	8.5	(20)	16	(20)	28	(20)	70	(40)	120	(40)	165	(60)	
				2A	2-Step reduction	2.3	(20)	3	(20)	5.4	(20)	10.5	(20)	17	(20)	42	(40)	72	(40)	85	(60)	
				3A	3-Step reduction	1.5	(20)	2	(20)	3.1	(20)	6	(20)	10	(20)	25	(40)	42	(40)	50	(60)	
				4A	4-Step reduction	0.8	(20)	1.2	(20)	2	(20)	4	(20)									
				5A	5-Step reduction	0.5	(20)	0.7	(20)	1.2	(20)	2.2	(20)									
			6A	6-Step reduction	0.3	(20)	0.4	(20)	0.8	(20)	1.2	(20)										
			E	Linear	FT	Tendril 1 / Full capacity	7	(20)	9	(20)	13.5	(20)	28	(20)	49	(20)	100	(40)	190	(40)		
		Equal %		1T	Tendril 1 / 1-Step reduction	4	(20)	5.5	(20)	8.5	(20)	16	(20)	28	(20)	70	(40)	120	(40)			
				2T	Tendril 1 / 2-Step reduction	2.3	(20)	3	(20)	5.4	(20)	10.5	(20)	17	(20)	42	(40)	72	(40)			
				3T	Tendril 1 / 3-Step reduction	1.5	(20)	2	(20)	3.1	(20)	6	(20)	10	(20)	25	(40)	42	(40)			
				4T	Tendril 1 / 4-Step reduction	0.8	(20)	1.2	(20)	2	(20)	4	(20)									
	5T	Tendril 1 / 5-Step reduction		0.5	(20)	0.7	(20)	1.2	(20)	2.2	(20)											
C	Micro plug type	L	Linear	FC	Full capacity	0.1	(20)	0.1	(20)	0.1	(20)											
				1A	1-Step reduction	0.06	(20)	0.06	(20)	0.06	(20)											
				2A	2-Step reduction	0.03	(20)	0.03	(20)	0.03	(20)											
				3A	3-Step reduction	0.01	(20)	0.01	(20)	0.01	(20)											
				4A	4-Step reduction	0.006	(20)	0.006	(15)	0.006	(20)											
				5A	5-Step reduction	0.003	(20)	0.003	(15)	0.003	(20)											
Y	Special	Y	Special	YY	Special	Contact Valmet for Cv details																

- \* Rated Cv is separated depending on the trim type & trim characteristic.
- \* Optional rated Cv to meet to specific Cv are available.
- \* (Str) is the valve stroke.
- \* For trims without the specified Cv values, please contact Valmet.

Subject to change without prior notice.

Neles, Neles Easyflow, Jamesbury, Stonel, Valvcon and Flowrox, and certain other trademarks, are either registered trademarks or trademarks of Valmet Oyj or its subsidiaries in the United States and/or in other countries.

For more information [www.neles.com/trademarks](http://www.neles.com/trademarks)

**Neles Finland Oy (part of Valmet)**

Vanha Porvoontie 229, 01380 Vantaa, Finland.

Tel. +358 10 417 5000.

[www.valmet.com/flowcontrol](http://www.valmet.com/flowcontrol)



# Neles™ Omega™ globe valves Series GM

The series GM, Omega trim valves are most suitable for high pressure drop applications of both compressible and incompressible fluids as it enables the flow velocity to be controlled through the multistage Omega trim. Also, series GM range of valves combines high integrity features, such as 2 or 3 dimensional flow path multistage trim, a high flow capacity and a wide range of 'OMEGA' trim designs. This means it is ideally suited to meet the various severe service process control requirements that are demanded from a wide range of industry related applications. The 'OMEGA' trim design is a multi-passage, multiturn disk stack trim. There are 2-32 turns designs available depending on pressure drop and potential for cavitation. The fluid passes through the flow passage generated by the Omega multistage trim. The pressure drop is staged across the stacks so that the pressure drop progressively reduces as it passes through the steps of the trim. This gives excellent resistance to cavitation on high pressure drop applications. Standard valves are equipped with VD spring diaphragm actuators, VB or VC cylinder actuators with Neles™ intelligent valve controllers for precise flow control, extended operational life and performance monitoring on-line.

## Construction

- Various construction design available with a range of different end styles and connections
- The Omega standard balanced trim design is based on 2 or 3 dimensional multistage cage and balanced plug.
- The multistage trim shape defines the flow path through the valve and flow characteristics of the valve (linear, equal percentage or others), standard trim characteristic is linear.
- The balancing holes are located in the top of the plug. This trim is specially suited to high pressure drop application and is used in the majority of control applications.
- Wide variety of trims with different Cv and characteristics
- Both metal and soft seats are available depending the application
- Optional bellows seal for toxic or other applications where no stem seal leakage is allowed
- Wide material selection for different applications
- Many end connection styles available for different applications
- Extension bonnet design for wide temperature range

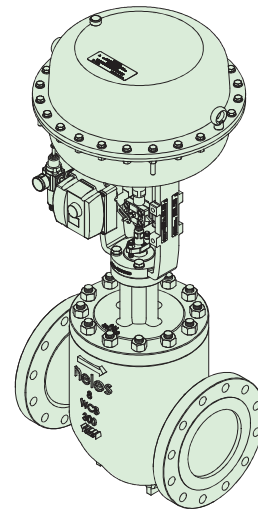

## Wide range of applications

- Suitable for gas, liquid and steam
- Wide temperature ranges from -196 ... +593 °C (-320 ... +1099 °F) with different bonnet constructions. Temperature limits -29 ... +425 °C / (-20 ... +797 °F) with standard bonnet construction, over +425 °C (+797 °F) and under -29 °C / (-20 °F) with extended bonnets
- Large variation of trim designs for multi-turns and passages for low-noise, and anti-cavitation applications
- Wide range of applicable noise control components, silencers, attenuate plates
- Inherently characterized trim offered in linear, and optionally equal percentage.
- Large range of trims per size allowing for wide rangeability in process conditions
- Clamped cage for heavy duty guiding on severe service applications
- High integrity cage guiding system
- Double packing available

## Benefits of 'OMEGA' trim applications

- Quick change trim and top entry construction for easy in-line maintenance
- Self guided components makes for easy valve assembly
- All trim components removable from the top side for easy maintenance
- Prolonged trim and valve life time
- Effective noise control
- Reduction of cavitation damage and pipe fatigue
- Stable process control
- Faster start-up, reduced system managing cost
- Neles™ digital valve controller with online diagnostics enables performance follow up and predictive maintenance
- Efficient asset management with any FDT frame application and excellent networking capabilities

### Accurate control & performance

- ND9000 digital valve controller for auto-calibration and accurate control
- Accurate and sensitive diaphragm and cylinder actuators
- Stable flow control with high rangeability
- Low-noise, anti-cavitation control and erosion resistant trims
- Streamline flow passage to secure capacity

### Safety and quality

- Rugged one piece body structure to minimize leakage paths and make the valve less insensitive from prone stress
- Strictly tested to ensure specified performance with quality assurance systems in according to ISO 9001
- Certified ISO 15848 fugitive emissions
- Certified CE/PED & ATEX, TSG & EAC (GOST-R)
- Certified SIL (Safety Integrity Level) in accordance to IEC61508

## Applications for 'OMEGA' trim

### Severe services in power plant

- Flow control for main & start-up feed pump recirculation
- Main & booster feed water control
- Condensate booster pump recirculation
- Deaerator level control
- Turbine by-pass & steam generator blow down
- Auxiliary steam shoot blower control
- Boiler start-up main steam spray
- Pressurizer & POSRV
- Chemical & Volume Control System (CVCS) letdown
- HP coolant injection
- Atmospheric steam dump
- Atmospheric venting silencer

### Severe services in oil & gas plant

- Compressor anti-surge, kick back & recycle
- Pump minimum flow & recirculation
- Blow down discharge to vent flare
- Reactor de-pressurization
- Turbo expander by-pass
- Gas injection lift control
- Gas storage pressure letdown
- Gas flow regulation
- Pipeline anti-surge
- Heavy oil letdown
- Ethylene letdown
- Steam vent to atmosphere
- Well head choke valves

## Different trim designs

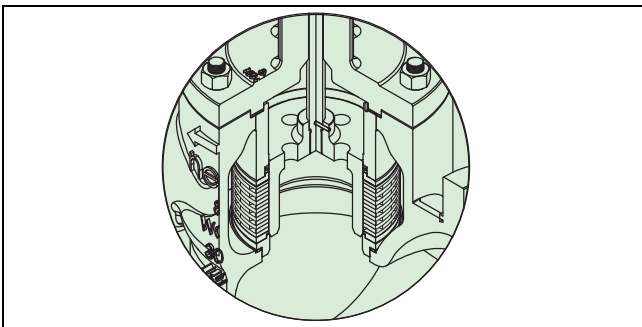

### Omega quick change, Standard balanced trim

The Omega standard balanced trim design is based on 2 or 3 dimensional labyrinth disk stack cage and balanced plug. The opened disk stack shape defines the flow path through the valve and flow characteristics of the valve (linear, equal percentage, others), standard trim characteristic is linear. The balancing holes are located in the top of the plug. This trim is specially suited to high pressure drop application and is used in the majority of control applications.

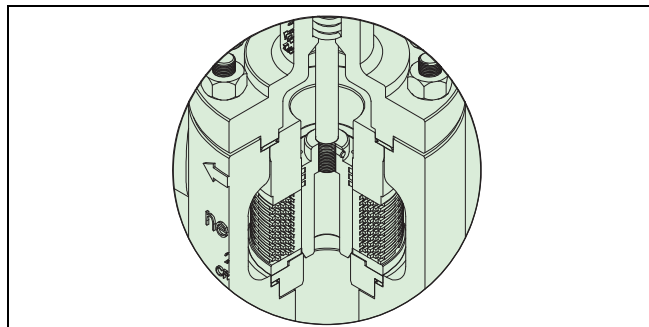

### Multiple graphite seal rings, Omega trim

Multiple graphite seal ring construction is ideal solution for high temperature applications requiring FCI 70-2 Class III or IV tightness. It can be used in various high temperature applications, including high pressure service. The trim is compatible with both standard cage and Tendril trims.

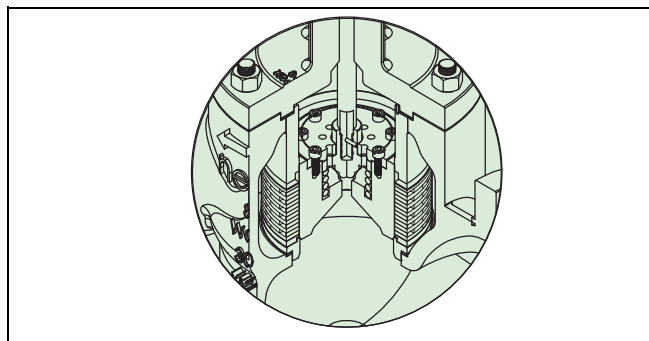

### Omega quick change, Pilot balanced trim

Pilot balanced trim construction is designed with a special pilot plug & seat built-in the main plug. The design gives excellent seat tightness on high pressure drop and high temperature applications. The design applicable TSO (Tight shut off, seat leakage class V) requirement in high temperature services.

## GM Application guide

### Temperature range

PTFE + Graphite pressure energized seal with metal seat: -56...+260 °C

PTFE + Graphite + Carbon pressure energized seal with metal seat: -56...+320 °C  
 PTFE pressure energized seal with metal seat: -196...+232 °C

Multiple graphite seals with metal seat: -56...+540 °C  
 Pilot balanced trim with metal seat: -56...+593 °C

### Pressure energized seal ring construction

ANSI FCI 70-2 Class IV and V available with metal and soft seat.

### Seal-ring & seat solutions for GM valve trims

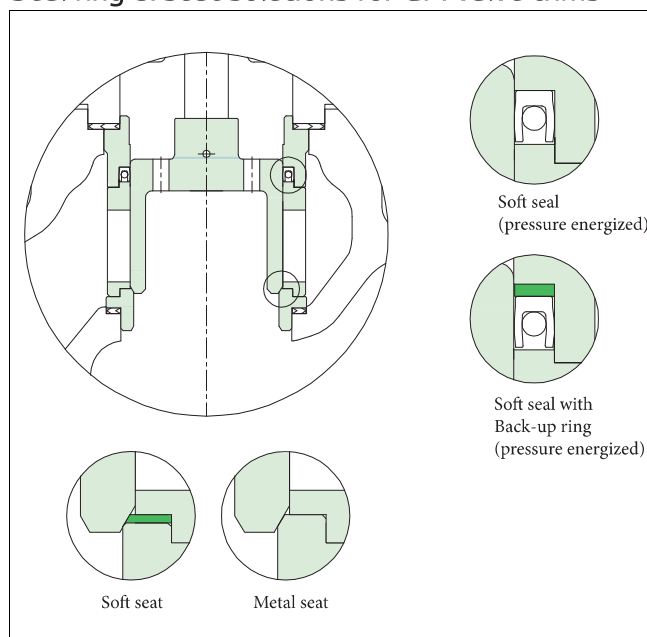

### High temperature seal ring construction

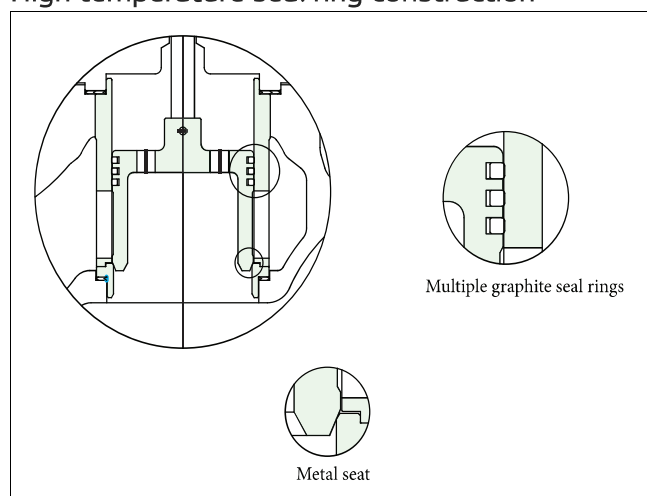

### Temperature range with different body and stud/nut materials

Body, bonnet material	Stud, nut material	Temp. range (°C)	Sign
Carbon steel (WCB, A105)	ASTM A193-B7M STUD / ASTM A194-2HM NUT	-29...+425	G
Stainless steel (CF3, CF8, CF3M, CF8M)	ASTM A193-B8M / ASTM A194 -8M NUT	-196...+425	D
Cr.Mo. Steel (WC6, F11, WC9, F22, C12A, F91)	ASTM A193-B16 STUD ASTM A194-4 NUT	-29...+593	H

### Trim materials

GM, Trim				Temp. range (°C)	Sign
Plug	Stem	Seat	Disk		
SUS 420J2	XM-19	SUS420 J2	SUS420 J2	-10...+540	P2XVXS1 P2X
CF8M + HCr	316 SS + HCr	CF8M	316L SS	-196...+425	T6XTCS1 R4X
Inconel 625, 718, 750				-196...+645	*

\* Please contact Valmet.

### Gasket applications

Body, bonnet material	Gasket material	Temp. range (°C)	Sign
Carbon steel WCB, A105	S/W (Spiral wound) 316L + Graphite	-29...+425	S
Stainless steel CF8, CF8M, CF3, CF3M	S/W (Spiral wound) 316L + Graphite	-56...+425	S
	S/W (Spiral wound) 316L + PTFE	-196...+232	L
Cr.Mo. Steel WC6, WC9, F22, C12A, F91	S/W (Spiral wound) 316L + Hi-Graphite	-56...+593	H

### Packing applications

Packing material	Temp. range (°C)	Pressure class	Sign
PTFE + Carbon fiber (Braided TEF + Graphite), standard	-196...+260	Up to CL900	G
PTFE V-Ring	-196...+232	Up to CL900	T
Graphite (with Mold + Braided)	-56...+400	Up to CL2500	F*
Hi-Graphite (with Mold + Braided)	-56...+593	Up to CL2500	H

\* Graphite packing with low emission, live loaded construction can be applicable up to 425 °C.

### Flow direction

Series	General plug (Balanced plug) & High temp balanced plug		Pilot balanced plug	Unbalanced plug
	Disk stack			
	General (Gas)	General (Liquid)	General	General
GM	FTO	FTC	FTC	FTO
AM	FTO	FTC	FTC	FTO

FTO: Flow to open  
 FTC: Flow to close

### Cv ratio

100: 1

### Flow characteristics

Linear, equal percentage or other customized characteristic.

## GM, ratings & end connetions

Valve size DN / Inch	GM, ASME ratings										
	Class 150 ... 600				Class 900 ... 1500				Class 2500		
	RF	RTJ	SW	BW	RF	RTJ	SW	BW	RF	RTJ	BW
25 / 1	O	O	O	O	O	O	O	O		O	O
40 / 1-1/2	O	O	O	O	O	O	O	O		O	O
50 / 2	O	O	O	O	O	O	O	O		O	O
80 / 3	O	O		O	O	O		O		O	O
100 / 4	O	O		O	O	O		O		O	O
150 / 6	O	O		O	O	O		O		O	O
200 / 8	O	O		O	O	O		O		O	O
250 / 10	O	O		O	O	O		O		O	O
300 / 12	O	O		O	O	O		O		O	O
350 / 14	O	O		O	O	O		O		O	O
400 / 16	O	O		O	O	O		O		O	O

\*Note 1. RF: Raised Face Flange, RTJ: Ring Joint, SW: Socket Weld, BW: Butt Weld.  
 Bigger sizes are available, please contact Valmet.

## GM, Components and materials

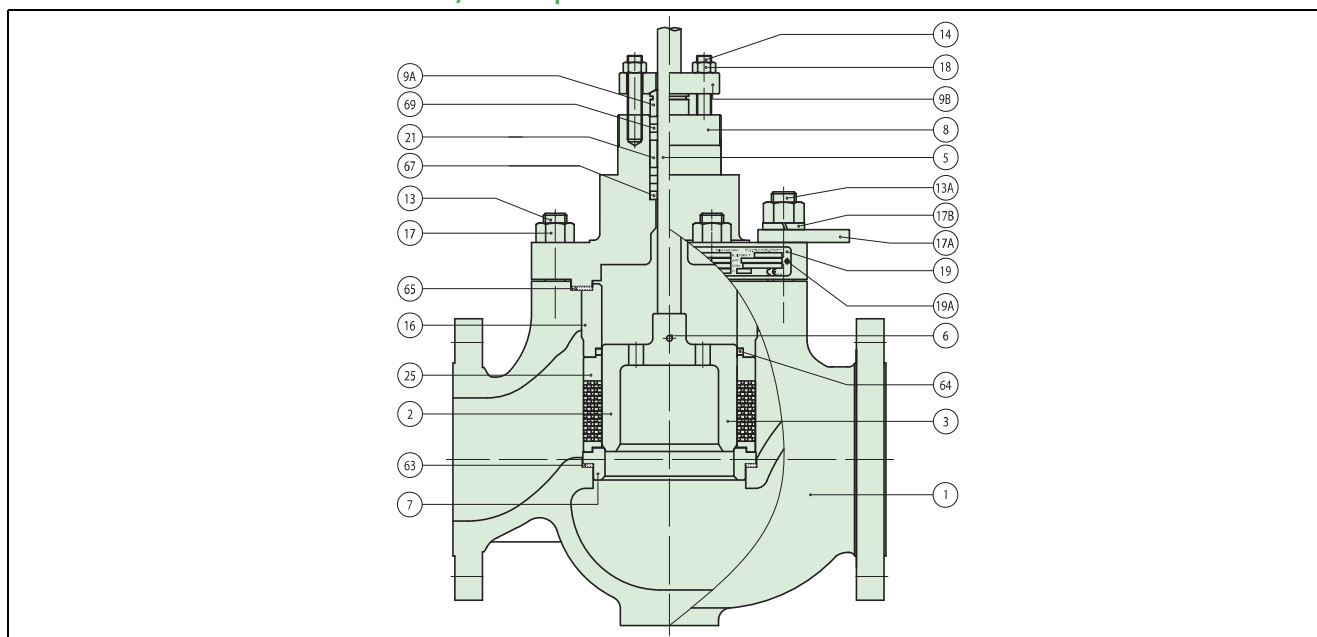

Body material: Carbon steel or alloy steel			Body material: Stainless steel	
Part no.	Description	Material	Material	Spare
1	BODY	A216 WCB / ALLOY STEEL AVAILABLE	A351 CF8M	
2	PLUG SET	420(J2) SS / 630 SS	316 SS / 316 SS	Cat 3
3*	PLUG	420(J2) STAINLESS STEEL	316 STAINLESS STEEL	Cat 3
5*	STEM	630 STAINLESS STEEL + HCr	630 STAINLESS STEEL + HCr	Cat 3
6*	PLUG PIN	316 STAINLESS STEEL	316 STAINLESS STEEL	Cat 3
7	SEAT RING	420 STAINLESS STEEL	316 STAINLESS STEEL	Cat 3
8	BONNET	A216 WCB / ALLOY STEEL AVAILABLE	A351 CF8M	
9A	GLAND	304 STAINLESS STEEL	304 STAINLESS STEEL	
9B	GLAND FLANGE	A351 CF8	A351 CF8	
13 / 13A	STUD	A193 Gr.B7M	A193 Gr. B8M	
14	STUD	A193 Gr.B8M	A193 Gr. B8M	
16	CAGE GUIDE	420(J2) STAINLESS STEEL	420(J2) STAINLESS STEEL	Cat 3
17	HEXAGON NUT	A194 Gr.2HM	A194 Gr. 8M	
17A	LIFTING PLATE	JIS G3101-SS400	JIS G3101-SS400	
17B	SPRING WASHER	AISI 304	AISI 304	
18	HEXAGON NUT	A194 Gr.8M	A194 Gr. 8M	
19	IDENTIFICATION PLATE	304 STAINLESS STEEL	304 STAINLESS STEEL	
19A	RIVET	304 STAINLESS STEEL	304 STAINLESS STEEL	
21	LANTERN RING	304 STAINLESS STEEL	304 STAINLESS STEEL	
25	DISK STACK	420(J2) STAINLESS STEEL	316L STAINLESS STEEL	Cat 3
63	SEAT GASKET	S/W GASKET, 316L SS + GRAPHITE	S/W GASKET, 316L SS + GRAPHITE	Cat 1
64	SEAL RING	PTFE + GRAPHITE	PTFE + GRAPHITE	Cat 1
65	BODY GASKET	S/W GASKET, 316L SS + GRAPHITE	S/W GASKET, 316L SS + GRAPHITE	Cat 1
67	PACKING SPACER	304 STAINLESS STEEL	304 STAINLESS STEEL	
69	PACKING RING	PTFE + Carbon Fiber	GRAPHITE	Cat 1

## Note.

1. Plug/Seat hard facing (Cobalt based alloy) & Soft seat are available
2. Materials description  
316 SS : ASTM A276 TP316 or JIS 316 St. Steel  
410 SS : ASTM A276 TP410 or JIS 410 St. Steel  
420 SS : ASTM A276 TP420 or JIS 420 St. Steel  
440C SS : ASTM A276 TP440C or JIS 440C St. Steel  
17-4PH : ASTM A564 630 (H1100) or JIS 630 (H1100) St. Steel
3. Above standard materials to be applicable depending on specific service conditions, other optional materials to consult Valmet.
4. Optional materials to meet to requirements of NACE MR 01-75 are available
5. The materials are subject to change as equivalent depending on detail design
6. The part no. 3, 5, 6 are delivered as a set with no. 2

## Note.

1. Plug/Seat hard facing (Cobalt based alloy) & Soft seat are available
2. Materials description  
316 SS : ASTM A276 TP316 or JIS 316 St. Steel  
420 SS : ASTM A276 TP420 or JIS 420 St. Steel
3. Above standard materials to be applicable depending on specific service conditions, other optional materials to consult Valmet.
4. Cryogenic application : ASTM A320 B8M & 8M for studs(13) and nuts(17)
5. Optional materials to meet to requirements of NACE MR 01-75 are available
6. The materials are subject to change as equivalent depending on detail design
7. The part no. 3, 5, 6 are delivered as a set with no. 2

## OMEGA design principals

- The value of pressure drop in the omega trim can be bigger than the conventional cage trims through the number of turns with multi-path and multi-stage.
- The value of pressure drop in the omega trim is a sum of the 'dynamic pressure in omega trim' and the 'dynamic pressure in valve design'.

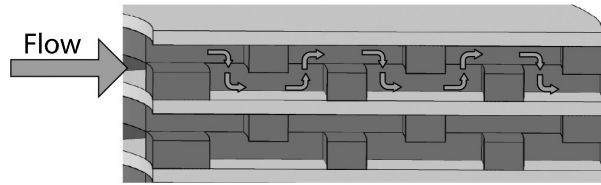

## Trim outlet velocity and kinetic energy limitation

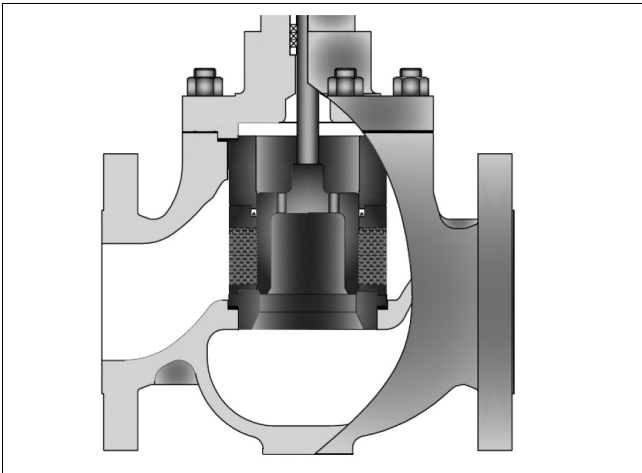

The limitation data is based on ISA04-P211.

- The exceed velocity will be made in vibration and erosive damage to the body, trim and outlet pipe wall.
- The exceed energy will be made in mechanical vibration and erosive damage to the body, trim and outlet pipe wall.

Valve trim outlet fluid kinetic energy density criteria

Service conditions	Water velocity	Oil velocity (Gf=0.8)	Air velocity (p=7 Mpa)	Kinetic energy
	m/s (ft/s)	m/s (ft/s)	m/s (ft/s)	kpa (psi)
Continuous service, single phase fluid	30 (100)	34 (112)	105 (345)	480 (70)
Cavitating and multi-phase fluids	23 (75)	26 (84)	-	275 (40)
Vibration sensitive system	12 (40)	14 (45)	42 (140)	75 (11)

## Packing constructions

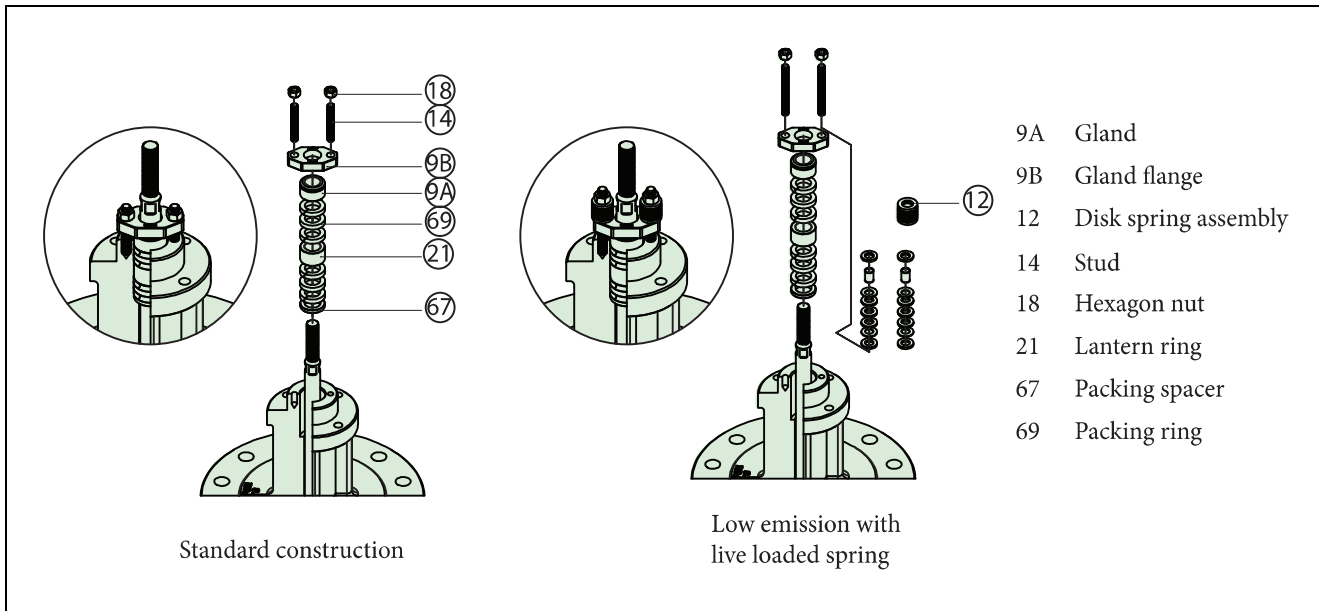

## GM Series Cv vs Travel Standard OMEGA

ANSI Class: 150# ... 2500#

Size: 1" ... 16"

Flow Characteristic: linear

Valve travel [%]							10	20	30	40	50	60	70	80	90	100	
F <sub>L</sub>							1.00	1.00	1.00	1.00	1.00	1.00	1.00	1.00	1.00	1.00	1.00
Valve size		Orifice diameter			Travel		Rated Cv										
inch	mm	sign	inch	mm	inch	mm											
1	25	FC	0.6	15.7	1.2	30	0.69	1.37	2.06	2.75	3.43	4.12	4.80	5.49	6.18	7	
		1A					0.29	0.59	0.88	1.18	1.47	1.76	2.06	2.35	2.65	3	
		2A					0.16	0.31	0.47	0.63	0.78	0.94	1.10	1.25	1.41	1.6	
		3A					0.08	0.16	0.24	0.31	0.39	0.47	0.55	0.63	0.71	0.8	
1-1/2	40	FC	0.9	23.0	1.2	30	1.57	3.14	4.71	6.28	7.84	9.41	10.98	12.55	14.12	16	
		1A					0.79	1.57	2.35	3.14	3.92	4.71	5.49	6.27	7.06	8	
		2A					0.39	0.78	1.18	1.57	1.96	2.35	2.74	3.14	3.53	4	
		3A					0.20	0.39	0.59	0.78	0.98	1.18	1.37	1.57	1.76	2	
2	50	FC	1.5	37.0	1.6	40	2.55	5.10	7.65	10.20	12.75	15.29	17.84	20.39	22.94	26	
		1A					1.18	2.35	3.53	4.71	5.88	7.06	8.23	9.41	10.59	12	
		2A					0.59	1.18	1.77	2.35	2.94	3.53	4.12	4.71	5.29	6	
		3A					0.29	0.59	0.88	1.18	1.47	1.76	2.06	2.35	2.65	3	
3	80	FC	3.0	77.0	2.0	50	5.30	10.59	15.89	21.18	26.47	31.76	37.05	42.35	47.64	54	
		1A					2.75	5.49	8.24	10.98	13.73	16.47	19.21	21.96	24.70	28	
		2A					1.37	2.75	4.12	5.49	6.86	8.23	9.61	10.98	12.35	14	
		3A					0.69	1.37	2.06	2.75	3.43	4.12	4.80	5.49	6.18	7	
4	100	FC	3.6	91.0	2.0	50	8.2	16.5	24.7	32.9	41.2	49.4	57.6	65.9	74.1	84	
		1A					5.1	10.2	15.3	20.4	25.5	30.6	35.7	40.8	45.9	52	
		2A					2.6	5.1	7.6	10.2	12.7	15.3	17.8	20.4	22.9	26	
		3A					1.4	2.7	4.1	5.5	6.9	8.2	9.6	11.0	12.4	14	
6	150	FC	4.1	133.6	2.4	60	14.3	28.6	43.0	57.3	71.6	85.9	100.2	114.5	128.8	146	
		1A					8.8	17.7	26.5	35.3	44.1	52.9	61.8	70.6	79.4	90	
		2A					4.4	8.8	13.2	17.6	22.1	26.5	30.9	35.3	39.7	45	
		3A					2.2	4.3	6.5	8.6	10.8	12.9	15.1	17.3	19.4	22	
8	200	FC	6.9	175.5	3.1	70	24.7	49.4	74.1	98.8	123.5	148.2	172.9	197.6	222.3	252	
		1A					15.3	30.6	45.9	61.2	76.5	91.8	107.0	122.3	137.6	156	
		2A					7.7	15.3	22.9	30.6	38.2	45.9	53.5	61.2	68.8	78	
		3A					3.9	7.8	11.8	15.7	19.6	23.5	27.4	31.4	35.3	40	
10	250	FC	8.1	214.2	3.5	80	37.7	75.3	113.0	150.6	188.2	225.9	263.5	301.1	338.8	384	
		1A					23.0	45.9	68.8	91.8	114.7	137.6	160.6	183.5	206.4	234	
		2A					11.4	22.8	34.1	45.5	56.9	68.2	79.6	91.0	102.3	116	
		3A					5.7	11.4	17.1	22.7	28.4	34.1	39.8	45.5	51.2	58	
12	300	FC	10.4	264.8	4.7	120	55.0	109.9	164.8	219.6	274.5	329.4	384.3	439.2	494.0	560	
		1A					33.4	66.7	100.0	133.3	166.7	200.0	233.3	266.6	299.9	340	
		2A					16.7	33.4	50.0	66.7	83.3	100.0	116.7	133.3	150.0	170	
		3A					8.2	16.5	24.7	32.9	41.2	49.4	57.6	65.9	74.1	84	
14	350	FC	12.4	315.5	5.5	140	75.6	151.1	226.5	302.0	377.5	452.9	528.4	603.8	679.3	770	
		1A					46.1	92.2	138.3	184.3	230.4	276.5	322.5	368.6	414.6	470	
		2A					23.0	45.9	68.8	91.8	114.7	137.6	160.6	183.5	206.4	234	
		3A					11.4	22.8	34.1	45.5	56.9	68.2	79.6	91.0	102.3	116	
16	400	FC	14.1	357.7	6.3	160	100.0	200.1	300.1	400.0	500.0	600.0	699.9	799.9	899.8	1020	
		1A					61.2	122.4	183.6	244.7	305.9	367.0	428.2	489.3	550.5	624	
		2A					30.4	60.8	91.2	121.6	152.0	182.3	212.7	243.1	273.5	310	
		3A					15.1	30.2	45.3	60.4	75.5	90.6	105.7	120.8	135.9	154	

## NOTE

C<sub>v</sub>: Valve flow coefficientF<sub>L</sub>: Liquid pressure recovery factor

FC: Full capacity    1A: 1-Step reduction    2A: 2-Step reduction    3A: 3-Step reduction

## GM, Valve dimensions and weights

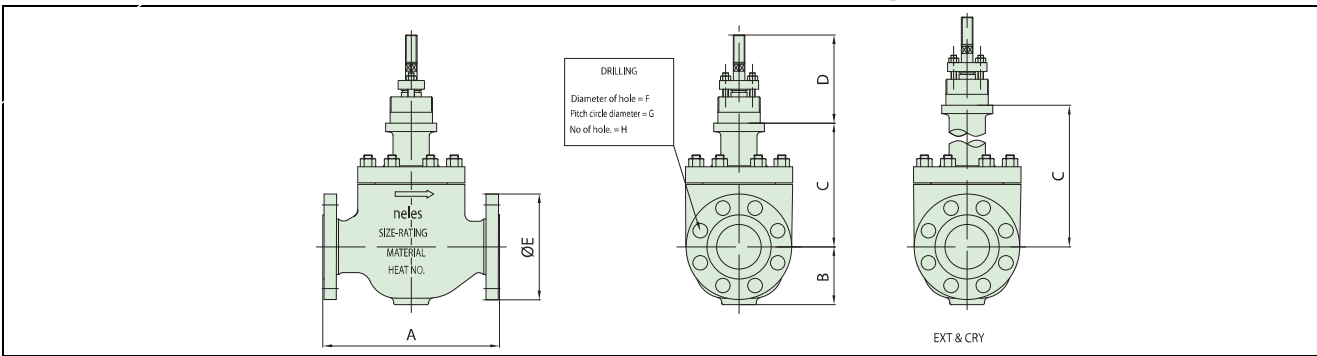

### 150 #/ 300 #/ 600 #

Dimension (mm)	A			B			C			D	E			F			G			H			Weight (kg) (Approximate)		
	150#	300#	600#	150#	300#	600#	STD	EXT	CRY	COMMON	150#	300#	600#	150#	300#	600#	150#	300#	600#	150#	300#	600#	150#	300#	600#
25	184	197	210	55	63	63	142	250	400	110	110	125	125	15.9	19.1	19.1	79.4	88.9	88.9	4	4	4	14	15	23
40	222	235	251	65	78	78	161	269	419	110	125	155	155	15.9	22.2	22.2	98.4	114.3	114.3	4	4	4	22	23	27
50	254	267	286	83	83	83	178	333	458	110	150	165	165	19.1	19.1	19.1	120.7	127	127	4	8	8	30	32	40
80	298	318	337	109	109	120	222	395	545	115	190	210	210	19.1	22.2	22.2	152.4	168.3	168.3	4	8	8	65	67	72
100	352	368	394	135	135	135	248	402	552	140	230	255	275	19.1	22.2	25.4	190.5	200	215.9	8	8	8	100	103	112
150	451	473	508	170	170	178	340	467	642	150	280	320	355	22.2	22.2	28.6	241.3	269.9	292.1	8	12	12	185	195	240
200	543	568	610	230	230	230	451	557	732	150	345	380	420	22.2	25.4	31.8	298.5	330.2	349.2	8	12	12	363	385	443
250	673	708	752	275	275	275	488	670	870	150	405	445	510	25.4	28.6	34.9	362	387.4	431.8	12	16	16	552	595	681
300	737	775	819	350	350	350	543	716	916	140	485	520	560	25.4	31.8	34.9	431.8	450.8	489	12	16	20	905	955	1020
350	889	927	972	385	385	385	616	846	1046	210	535	585	605	28.6	31.8	38.1	476.3	514.4	527	12	20	20	1170	1230	1311
400	1016	1057	1108	440	440	440	692	909	1109	220	595	650	685	28.6	34.9	41.3	539.8	571.5	603.2	16	20	20	1380	1460	1587

Dimension (inch)	A			B			C			D	E			F			G			H			Weight (lbs) (Approximate)		
	150#	300#	600#	150#	300#	600#	STD	EXT	CRY	COMMON	150#	300#	600#	150#	300#	600#	150#	300#	600#	150#	300#	600#	150#	300#	600#
1"	7.2	7.8	8.3	2.2	2.5	2.5	5.6	9.8	15.7	4.3	4.3	4.9	4.9	0.6	0.8	0.8	3.1	3.5	3.5	4	4	4	31	33	51
1-1/2"	8.7	9.3	9.9	2.6	3.1	3.1	6.3	10.6	16.5	4.3	4.9	6.1	6.1	0.6	0.9	0.9	3.9	4.5	4.5	4	4	4	49	51	60
2"	10	10.5	11.3	3.3	3.3	3.3	7	13.1	18	4.3	5.9	6.5	6.5	0.8	0.8	0.8	4.8	5	5	4	8	8	66	71	88
3"	11.7	12.5	13.3	4.3	4.3	4.7	8.7	15.6	21.5	4.5	7.5	8.3	8.3	0.8	0.9	0.9	6	6.6	6.6	4	8	8	143	148	159
4"	13.9	14.5	15.5	5.3	5.3	5.3	9.8	15.8	21.7	5.5	9.1	10	10.8	0.8	0.9	1	7.5	7.9	8.5	8	8	8	221	227	247
6"	17.8	18.6	20	6.7	6.7	7	13.4	18.4	25.7	5.9	11	12.6	14	0.9	0.9	1.1	9.5	10.6	11.5	8	12	12	408	430	529
8"	21.4	22.4	24	9.1	9.1	9.1	17.8	21.9	28.8	5.9	13.6	15	16.5	0.9	1	1.3	11.8	13	13.7	8	12	12	800	849	977
10"	26.5	27.9	29.6	10.8	10.8	10.8	19.2	26.4	34.3	5.9	15.9	17.5	20.1	1	1.1	1.4	14.3	15.3	17	12	16	16	1217	1312	1501
12"	29	30.5	32.2	13.8	13.8	13.8	21.4	28.2	36.1	5.9	19.1	20.5	22	1	1.3	1.4	17	17.7	19.3	12	16	20	1995	2105	2249
14"	35	36.5	38.3	15.2	15.2	15.2	24.3	33.3	41.2	8.3	21.1	23	23.8	1.1	1.3	1.5	18.8	20.3	20.7	12	20	20	2579	2712	2890
16"	40	41.6	43.6	17.3	17.3	17.3	27.2	35.8	43.7	8.7	23.4	25.6	27	1.1	1.4	1.6	21.3	22.5	23.7	16	20	20	3042	3219	3499

### 900 #/ 1500 #

Dimension (mm)	A		B		C		D	E		F		G		H		Weight (kg)	
	900#	1500#	900#	1500#	STD	EXT	COMMON	900#	1500#	900#	1500#	900#	1500#	900#	1500#	900#	1500#
25	292	292	78	78	236	330	110	150	180	25.4	25.4	101.6	101.6	4	4	60	60
40	333	333	100	100	240	380	110	180	180	28.6	28.6	123.8	123.8	4	4	63	63
50	375	375	113	113	240	380	110	215	215	25.4	25.4	165.1	165.1	8	8	67	67
80	441	460	142	142	322	430	115	240	265	25.4	31.8	190.5	203.2	8	8	150	163
100	511	530	182	182	375	475	140	290	310	31.8	34.9	235	241.3	8	8	244	255
150	714	768	210	240	420	500	150	380	395	31.8	39	317.5	317.5	12	12	530	540
200	914	972	290	290	550	600	150	470	485	38.1	45	393.7	393.7	12	12	698	821
250	991	1067	310	350	600	700	150	545	585	38.1	51	469.9	482.6	16	12	955	1137
300	1130	1219	385	385	680	800	140	610	675	38.1	54	533.4	571.5	20	16	1180	1240
350	1257	1257	385	385	770	920	210	640	750	41.3	61	558.8	635	20	16	1387	1477
400	1422	1422	450	450	850	1050	220	705	825	44.5	67	616	704.8	20	16	1601	1721

Dimension (inch)	A		B		C		D	E		F		G		H		Weight (lbs)	
	900#	1500#	900#	1500#	STD	EXT	COMMON	900#	1500#	900#	1500#	900#	1500#	900#	1500#	900#	1500#
1"	11.5	11.5	3	3	9	13	4	5.9	7.1	1	1	4	4	4	4	132	132
1-1/2"	13.1	13.1	3.9	3.9	9.5	15	4	7.1	7.1	1.1	1.1	4.9	4.9	4	4	139	139
2"	14.8	14.8	4.4	4.4	9.5	15	4	8.5	8.5	1	1	6.5	6.5	8	8	148	148
3"	17.4	18.1	5.6	5.6	12.7	17	5	9.4	10.4	1	1.3	7.5	8	8	8	331	359
4"	20.1	20.9	7.2	7.2	15	19	6	11.4	12.2	1.3	1.4	9.3	9.5	8	8	538	562
6"	28.1	30.2	8.3	9.4	17	20	6	15	15.6	1.3	1.5	12.5	12.5	12	12	1168	1191
8"	36	38.3	11.4	11.4	22	24	6	18.5	19.1	1.5	1.8	15.5	15.5	12	12	1539	1810
10"	39	42	12.2	13.8	24	28	6	21.5	23	1.5	2	18.5	19	16	12	2105	2507
12"	44.5	48	15.2	15.2	27	31	6	24	26.6	1.5	2.1	21	22.5	20	16	2602	2734
14"	49.5	49.5	15.2	15.2	30	36	8	25.2	29.5	1.6	2.4	22	25	20	16	3058	3256
16"	56	56	17.7	17.7	33	41	8	27.8	32.5	1.8	2.6	24.3	27.7	20	16	3530	3794

Bigger sizes and ASME class 2500 ratings are available, please contact Valmet.

## How to order

### Globe Omega trim, multi-stage type, series GM

1.	2.	3.	4.	5.	6.	7.	8.	9.	10.	11.	12.	13.	14.	15.	16.	17.	18.	19.	20.	21.	22.
GM	02	H	Z	B	J2	B	P2	X	BC	S1	P2	X	S	G	G	S	G	X	A	E	FG

#### Valve constructions

1.	Valve series	
GM	Globe Omega trim, multi-stage type	

2.	Body size			
01	1" / DN 25	1H	1.5" / DN 40	
02	2" / DN 50	03	3" / DN 80	
04	4" / DN 100	06	6" / DN 150	
08	8" / DN 200	10	10" / DN 250	
12	12" / DN 300	14	14" / DN 350	
16	16" / DN 400	18	18" / DN 450	
20	20" / DN 500	24	24" / DN 600	
YY	Special			

3.	Pressure rating			
C	ASME class 150	D	ASME class 300	
F	ASME class 600	G	ASME class 900	
H	ASME class 1500	I	ASME Class 2500	
J	EN PN 10	K	EN PN 16	
L	EN PN 25	M	EN PN 40	
N	EN PN 63	P	EN PN 100	
B	EN PN 160	E	EN PN 250	
Y	Special	R	JIS 10K	
T	JIS 20K			

4.	End connection	
W	Flanged RF, ASME B16.5	
C	Flanged RF, EN 1092-1	
Z	Ring joint flange, ASME B16.5	
V	Socket welding, ASME B16.11	
Q	Butt welding, ASME B16.25	
Y	Special	

5.	Bonnet construction	
	Bonnet type	Actuator connection
A	General	Applicable for VD_25/29/37
B	General	Applicable for VD_48/55
C	General	Applicable for VC_30, VB_32
D	General	Applicable for VC/VB_40/50/60/70
E	Extension	Applicable for VD_25/29/37
F	Extension	Applicable for VD_48/55
G	Extension	Applicable for VC_30, VB_32
H	Extension	Applicable for VC/VB_40/50/60/70
P	Cryogenic	Applicable for VD_25/29/37
Q	Cryogenic	Applicable for VD_48/55
R	Cryogenic	Applicable for VC_30, VB_32
S	Cryogenic	Applicable for VC/VB_40/50/60/70
Y	Special	Special

6.	Body material	
J2	A216 gr. WCB	
S6	A351 gr. CF8M	
S1	A351 gr. CF3M	
J4	A217 gr. WC6	
CG	A217 gr. WC9	
YY	Special	

- Bonnet material is equivalent to body material.

7.	Model code	
B	Model B	

#### Trim constructions

8.	Plug material	
	Material	Description
P2	CA40	General for carbon steel valve
T6	CF8M + HCr	General for stainless steel valve
YY	Special	Special materials

9.	Plug application	
X	Not applicable	
A	Cobalt based alloy	
Y	Special	

10.	Stem material	
	Material	Description
BC	630 SS + HCr	General for carbon steel valve
TC	316 SS + HCr	General for stainless steel valve
VX	XM-19	

11.	Seat type	
S1	Single metal seat	
YY	Special	

12.	Seat / disk stack material		
	seat	Disk stack	Cage guide
P2	CA40	SUS 420J2	CA40
R4	CF8M	316L SS	CF8M + HCr
YY	Special	Special	Special

13.	Seat application	
X	Not applicable	
A	Cobalt based alloy	
Y	Special	

#### Others

14.	Packing / bellows type	
S	General packing	
E	Low emission, Live loaded	
C	Bellows seal (316L SS, Formed)	
Y	Special	

15.	Packing material	
G	PTFE + Carbon fiber	
F	Graphite	
T	PTFE V-Ring	
C	PTFE + Carbon fiber (ATEX)	
H	Hi-Graphite	
Y	Special	

16.	Seal ring material	
G	PTFE + Graphite	
H	PTFE + Graphite + Carbon	
M	Graphite	
T	PTFE	
X	Not applicable	
Y	Special	

17.	Gasket material
S	S/W gasket type, 316L SS + Graphite
L	S/W gasket type, 316L SS + PTFE
H	S/W gasket type, 316L SS + Hi-Graphite
Y	Special

19.	Options
X	Not applicable
E	Anti-erosion
L	Lub. & Isol. valve
W	Water seal
Y	Special

18.	Stud / nut material
G	A193 gr. B7M / A194 gr. 2HM
D	A193 gr. B8M / A194 gr. 8M
K	A320 gr. B8M cl. 2 / A194 gr. 8M
H	A193 gr. B16 / A194 gr. 7
E	A453 gr. 660 / A453 gr. 660
Y	Special

\* ASME valve face to face length according to ISA 75.08. EN valve face to face length according to ISA 75.08.

\* The body, bonnet, trim materials are subject to change as equivalent depending on detail design.

\* See 'Neles Globe Type code Instruction' for further options and explanations.

\* Round bar material such as AISI 410SS (for A743 gr. CA 15), AISI 316SS (for A351 gr. CF8M), SUS420J2 (for A743 gr. CA40) and AISI 630SS (for A747 gr. CB7Cu-1) can be used depending on manufacturing process.

## Trim type & rated Cv

20. Sign	Trim type	21. Sign	Trim characteristic	22. Sign	Description	Rated Cv																		
						Body size and stroke																		
						1" Str.	1,5" Str.	2" Str.	3" Str.	4" Str.	6" Str.	8" Str.	10" Str.	12" Str.	14" Str.	16" Str.								
A	Balanced plug	L	Linear	FG	Full capa. / Gas	7 (20)	16 (20)	26 (40)	54 (50)	84 (50)	146 (60)	252 (70)	384 (80)	560 (120)	770 (140)	1020 (160)								
A	High temp. balanced plug				FL	Full capa. / Liquid																		
P	Pilot balanced plug				1G	1-Step red. / Gas	3 (20)	8 (20)	12 (40)	28 (50)	52 (50)	90 (60)	156 (70)	234 (80)	340 (120)	470 (140)	620 (160)							
U	Unbalanced plug				1L	1-Step red. / Liquid	1.6 (20)	4 (20)	6 (40)	14 (50)	26 (50)	45 (60)	78 (70)	116 (80)	170 (120)	234 (140)	372 (160)							
					2G	2-Step red. / Gas																		
					2L	2-Step red. / Liquid	0.8 (20)	2 (20)	3 (40)	7 (50)	14 (50)	22 (60)	40 (70)	58 (80)	84 (120)	116 (140)	224 (160)							
					3G	3-Step red. / Gas																		
					3L	3-Step red. / Liquid	5 (20)	10 (20)	18 (40)	38 (50)	60 (50)	104 (60)	176 (70)	268 (80)	390 (120)	540 (140)	710 (160)							
					Y	Special	YY	Special																
					E	Equal %	FG	Full capa. / Gas	5 (20)	10 (20)	18 (40)	38 (50)	60 (50)	104 (60)	176 (70)	268 (80)	390 (120)	540 (140)	710 (160)					
		FL	Full capa. / Liquid																					
		1G	1-Step red. / Gas	2.5 (20)				6 (20)	11 (40)	24 (50)	36 (50)	64 (60)	108 (70)	164 (80)	236 (120)	328 (140)	430 (160)							
		1L	1-Step red. / Liquid																					
		2G	2-Step red. / Gas	1.2 (20)				3 (20)	5 (40)	12 (50)	18 (50)	32 (60)	54 (70)	82 (80)	118 (120)	164 (140)	214 (160)							
		2L	2-Step red. / Liquid	0.6 (20)				1.5 (20)	2 (40)	6 (50)	9 (50)	16 (60)	27 (70)	40 (80)	60 (120)	82 (140)	106 (160)							
		3G	3-Step red. / Gas																					
		3L	3-Step red. / Liquid																					
		Y	Special	YY				Special	Please contact Valmet for more information															

- Rated Cv is different depending on trim type and characteristic.

- Str. : valve stroke length (mm). It should be matched with actuator stroke length.

Subject to change without prior notice.

Neles, Neles Easyflow, Jamesbury, Stonel, Valcon and Flowrox, and certain other trademarks, are either registered trademarks or trademarks of Valmet Oyj or its subsidiaries in the United States and/or in other countries.

For more information [www.neles.com/trademarks](http://www.neles.com/trademarks)

**Neles Finland Oy (part of Valmet)**

Vanha Porvoontie 229, 01380 Vantaa, Finland.

Tel. +358 10 417 5000.

[www.valmet.com/flowcontrol](http://www.valmet.com/flowcontrol)



## Neles™ gage-guided globe valves Series GB

Neles series GB cage-guided globe valves providing superior control performance and high reliability in wide range of applications. Standard units are equipped with Neles diaphragm or piston actuators and valve controllers for precise flow control, extended operation life and performance monitoring online.

### Construction

- Compact and lightweight construction
- Large range of trims with different Cv and characteristics per body size to fit many process conditions
- Both metal and soft seats are available depending on the application
- Optional bellows seal for toxic or other applications where no stem seal leakage is allowed
- Wide material selection for different applications
- Many end connection styles available for different applications
- Extension bonnet design for wide temperature range

### Accurate control

- Stable control with good rangeability
- ND9000 or NDX digital valve controller for auto-calibration and accurate control
- Accurate and sensitive diaphragm and piston actuators

### Wide range of applications

- Suitable for gas, liquid and steam
- Wide temperature ranges from -196... +593 °C / (-320 ... +1099 °F) with different bonnet constructions
- Large variation of trim designs from standard cage to Tendril 1 or Tendril 2 for low noise and anti-cavitation applications
- Various seat and seal ring options for wide range of applications

### Design application flexibility

- Wide range of applicable noise control components, silencers, baffle plates
- Inherently characterized trims offered in equal percentage, linear
- Large range of Cvs per body size allowing for wide applicable in process conditions
- High integrity cage guiding system and clamped cage for heavy duty guiding on severe service applications
- Low emission packings available



### Safety and quality

- Rugged one piece body to minimize the leak paths and makes the valve less prone to pipe stress
- Strictly tested to ensure specified performance with quality assurance systems in accordance to ISO 9001
- Certified ISO 15848 fugitive emissions
- Certified CE/PED & ATEX, TSG & EAC (GOST-R)
- Certified SIL(Safety Integrity Level) in accordance to IEC61508

### Easy maintenance

- Quick change trim and top entry construction for easy in-line maintenance
- Self guiding components for easy valve assembly
- Flow characteristics can be easily changed with interchangeable trim components
- ND digital valve controller with online diagnostics enables performance follow up and predictive maintenance
- Efficient asset management with any FDT frame application

## Different trim designs

### Conventional trim

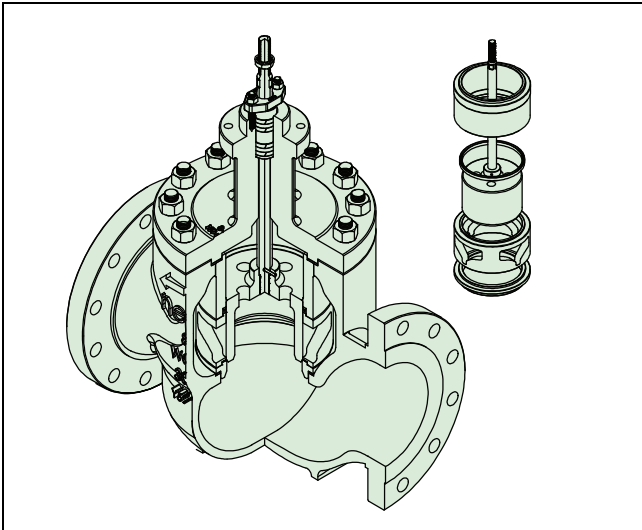

Pressure energized seal ring, standard cage trim

Standard cage trim is equipped with a specially designed window-shape cage and a balanced plug. The window area defines the flow path through the valve and the flow characteristic of the valve (linear, equal percentage etc.). The trim has balancing holes that are located on the top of the plug. This trim is suited for both high and low pressure drop application and is used in the majority of control applications.

### Tendril™ (Multi-hole) trim

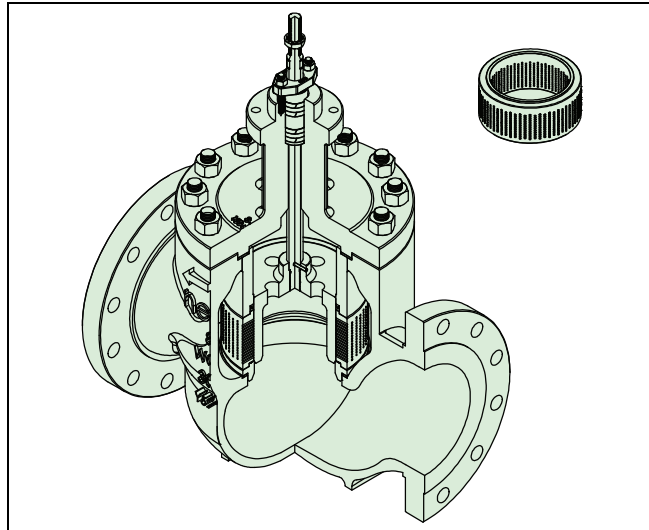

Tendril (Multi-hole) trim

Tendril is a multi-hole trim where the flow is divided through multiple holes in which pressure progressively reduces while passing through the trim. This gives excellent resistance to cavitation and reduces noise in high pressure drop applications. Tendril trim is available as Tendril 1 or Tendril 2 design depending on pressure drop and potential for cavitation.

### High temperature trim

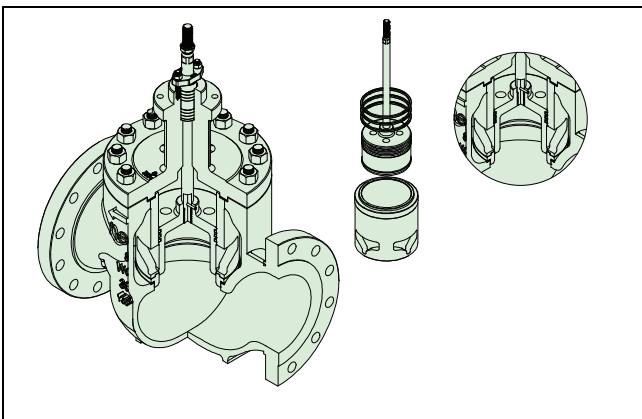

Multiple graphite seal rings, one-piece cage trim

Multiple graphite seal ring construction is ideal solution for high temperature applications requiring FCI 70-2 Class III or IV tightness. It can be used in various high temperature applications, including high pressure service. The trim is compatible with both standard cage and Tendril trims

### Pilot balanced trim

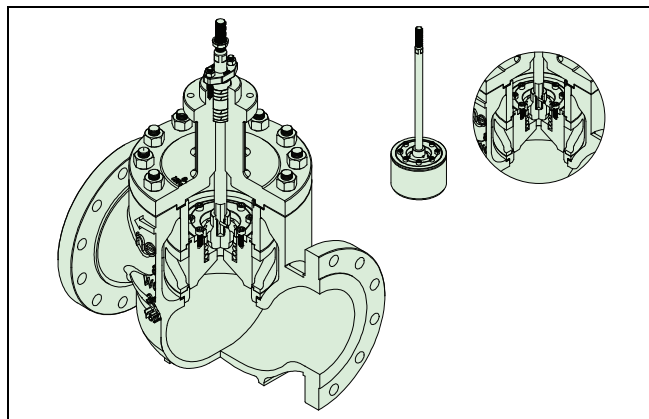

Pilot balanced trim

Pilot balanced trim construction is designed to be used in high temperature applications as the design is fully made of metal and it has only metal-to-metal sealing surfaces. The trim is suitable with both standard cage and Tendril trim. This design has excellent seat tightness up to FCI 70-2 Class V.

## Components & materials

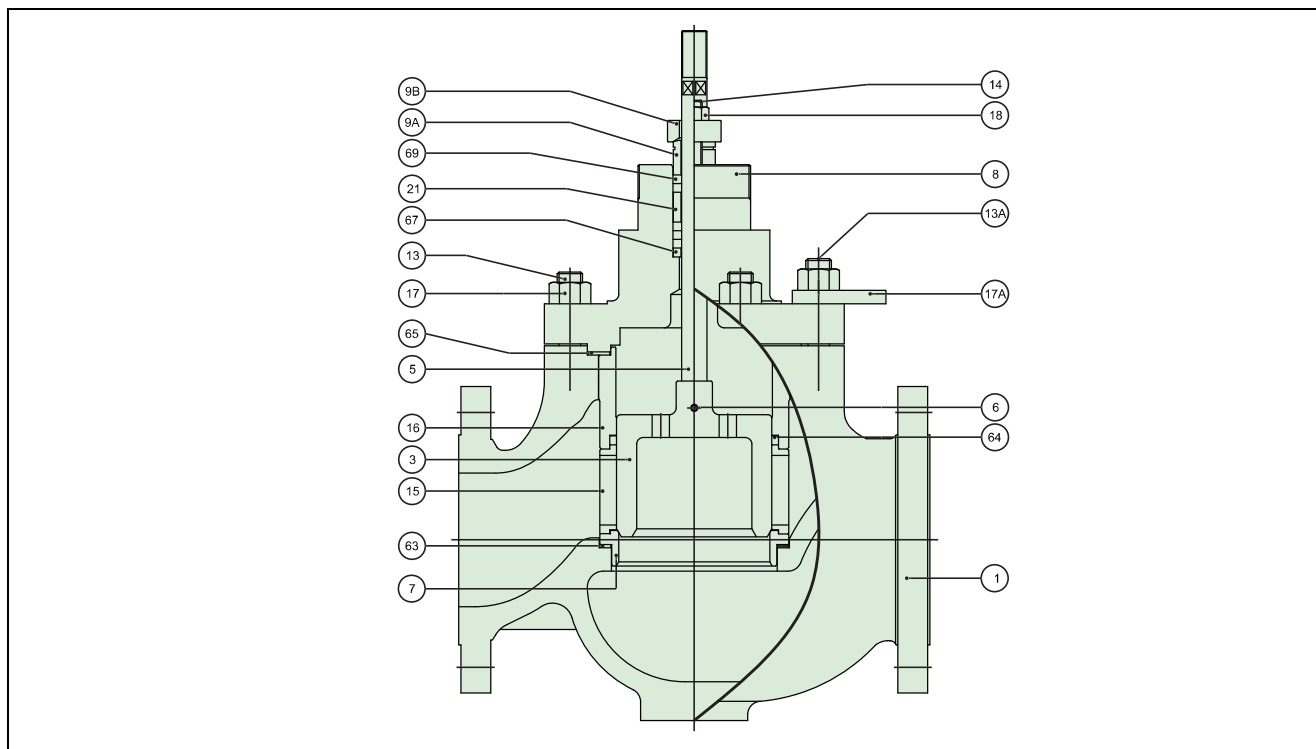

### Body material: Carbon steel or alloy steel

Part no.	Description	Material
1	BODY	A216 WCB / ALLOY STEEL AVAILABLE
2	PLUG SET	410 SS / 630 SS + HCr
3*	PLUG	410 STAINLESS STEEL
5*	STEM	630 STAINLESS STEEL + HCr
6*	PLUG PIN	316 STAINLESS STEEL
7	SEAT RING	410 STAINLESS STEEL
8	BONNET	A216 WCB / ALLOY STAINLESS STEEL
9A	GLAND	304 STAINLESS STEEL
9B	GLAND FLANGE	A351 CF8
13 / 13A	STUD	A193 Gr.B7M
14	STUD	A193 Gr.B8M
15	CAGE	630 STAINLESS STEEL + HCr
16	CAGE GUIDE	630 STAINLESS STEEL + HCr
17	HEXAGON NUT	A194 Gr.2HM
17A	LIFTING PLATE	JIS G3101-SS400
18	HEXAGON NUT	A194 Gr.8M
21	LANTERN RING	304 STAINLESS STEEL
63	SEAT GASKET	S/W GASKET, 316L SS + GRAPHITE
64	SEAL RING	PTFE + GRAPHITE
65	BODY GASKET	S/W GASKET, 316L SS + GRAPHITE
67	PACKING SPACER	304 STAINLESS STEEL
69	PACKING RING	PTFE + CARBON FIBER or GRAPHITE

**Note.**

1. Plug/Seat hard facing (Cobalt based alloy) & Soft seat are available
2. Materials description  
316 SS : ASTM A276 gr. 316 or JIS 316 stainless steel  
410 SS : ASTM A276 gr. 410 or JIS 410 stainless steel  
17-4PH : ASTM A564 630 (H1100) or JIS 630 (H1100) St. Steel
3. Above standard materials to be applicable depending on specific service conditions. Other optional materials to consult Valmet.
4. Optional materials to meet to requirements of NACE MR 01-75 are available
5. The materials are subject to change as equivalent depending on detail design
6. The part no. 3\*, 5\*, 6\* are delivered as a set with part no. 2

### Body material: Stainless steel

Material	Spare parts
A351 CF8M	
CF8M + HCr/ 316 SS + HCr	Cat 3
316 STAINLESS STEEL + HCr	Cat 3
316 STAINLESS STEEL + HCr	Cat 3
316 STAINLESS STEEL	Cat 3
316 STAINLESS STEEL	Cat 3
A351 CF8	
304 STAINLESS STEEL	
A351 CF8	
A193 Gr. B8M	
A193 Gr. B8M	
316 STAINLESS STEEL + HCr	Cat 3
316 STAINLESS STEEL + HCr	Cat 3
A194 Gr. 8M	
304 STAINLESS STEEL	
A194 Gr. 8M	
304 STAINLESS STEEL	
S/W GASKET, 316L SS + GRAPHITE	Cat 1
PTFE + GRAPHITE	Cat 1
S/W GASKET, 316L SS + GRAPHITE	Cat 1
304 STAINLESS STEEL	
PTFE + CARBON FIBER or GRAPHITE	Cat 1

**Note.**

1. Plug/Seat hard facing (Cobalt based alloy) & Soft seat are available
2. Materials description  
316 SS : ASTM A276 gr. 316 or JIS 316 stainless steel
3. Above standard materials to be applicable depending on specific service conditions, other optional materials to consult Neles.
4. Cryogenic application : ASTM A320 B7M & 8M for studs (13) and nuts (17)
5. Optional materials to meet to requirements of NACE MR 01-75 are available
6. The materials are subject to change as equivalent depending on detail design
7. The part no. 3\*, 5\*, 6\* are delivered as a set with part no. 2

## GB, Applications guide

### Temperature range

PTFE + Graphite pressure energized seal with metal seat:	-56...+260 °C
PTFE + Graphite + Carbon pressure energized seal with metal seat:	-56...+320 °C
PTFE pressure energized seal with metal seat:	-196...+232 °C
Multiple graphite seals with metal seat:	-56...+540 °C
Pilot balanced trim with metal seat:	-56...+593 °C

### Shut off classification

ANSI FCI 70-2 Class IV and V available with metal and soft seat.

### Pressure energized seal ring construction

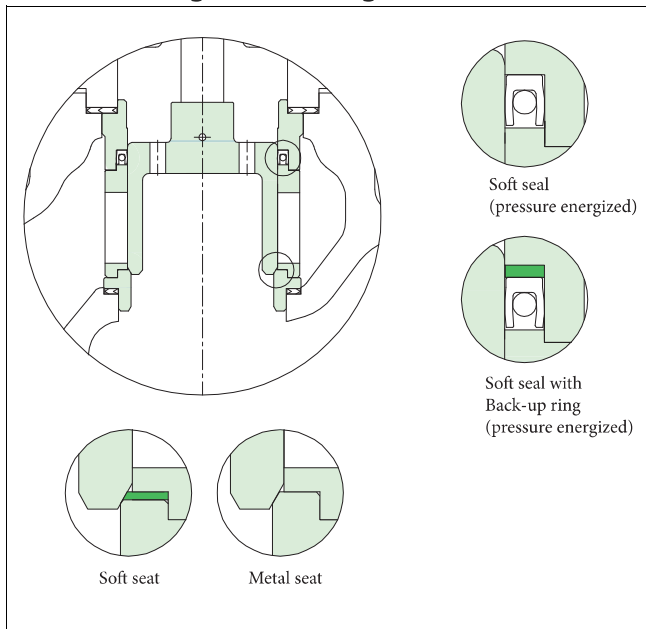

### High temperature seal ring construction

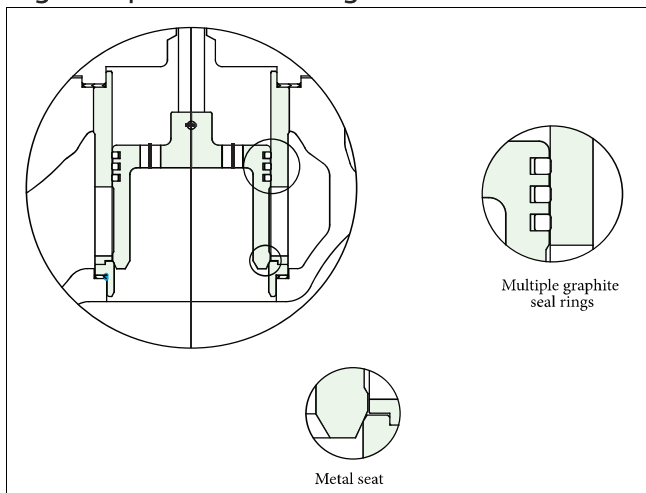

### Temperature range with different body and stud/nut materials

Body, bonnet material	Stud molt, nut application	Temp. range (°C)	Sign
Carbon steel (WCB, A105)	ASTM A193-B7M STUD / ASTM A194-2HM NUT	-29...+425	G
Stainless steel (CF3, CF8, CF3M, CF8M)	ASTM A193-B8M / ASTM A194 -8M NUT	-196...+425	D
Cr.Mo. Steel (WC6, F11, WC9, F22, C12A, F91)	ASTM A193-B16 STUD ASTM A194-4 NUT	-29...+593	H

### Trim materials

GB, Trim				Temp. range (°C)	Sign
Plug	Stem	Seat	Cage		
410 SS	630 SS + HCr	410 SS	630 SS + HCr	-29...+425	P1XBCSI1R1X
316 SS	316 SS + HCr	316 SS	316 SS + HCr	-196...+425	T6XTCSI1R6X
316 SS + Cobalt based	316 SS + HCr	316 SS + Cobalt based	316 SS + HCr	-196...+425	T6ATCSI1R6A
420 J2	XM-19 / Inconel 718	420 J2	420 J2	-10...+540	*
316 SS	316 SS + HCr	316 SS + PTFE	316 SS + HCr	-49...+232	*
Inconel 718	XM-19 / Inconel 718	F91	F91	-29...+593	*
Inconel 625, 718, 750				-196...+593	*

\*Please contact Valmet

### Gasket applications

Body, bonnet material	Gasket material	Temp. range (°C)	Sign
Carbon steel WCB, A105	S/W (Spiral wound) 316L SS + Graphite	-29...+425	S
Stainless steel CF8, CF8M, CF3, CF3M	S/W (Spiral wound) 316L SS + Graphite	-56...+593	S
	S/W (Spiral wound) 316L SS + PTFE	-196...+232	L
Cr.Mo. Steel WC6, WC9, F22, C12A, F91	S/W (Spiral wound) 316L SS + Hi Graphite	-29...+593	H

### Packing applications

Packing material	Temp (°C)	Pressure class	Sign
PTFE + Carbon Fiber (Braided TEF + Graphite)	-196...+260	Up to CL900	G
PTFE V-Ring	-49...+232	Up to CL600	T
Graphite (with Mold + Braided)	-196...+400	Up to CL2500	F*
Hi-Graphite (with Mold + Braided)	-54...+593	Up to CL2500	H

\*Graphite packing with low emission, live loaded construction can be applicable up to +450 °C

## Flow directions

Series	General plug & high temp balanced plug			Pilot balanced plug	
	Cage				
	General	Tendril (Gas)	Tendril (Liquid)	General	Tendril
GB	FTC*	FTO	FTC	FTC	FTC

\* FTO can be used  
 FTO: Flow to open  
 FTC: Flow to close

**Cv Ratio** 50 : 1

**Flow Characteristics** Equal percentage, linear

## GB, Ratings & end connections

Valve size DN / Inch	GB, ASME ratings										
	Class 150 ... 600				Class 900 ... 1500				Class 2500		
	RF	RTJ	SW	BW	RF	RTJ	SW	BW	RF	RTJ	BW
50 / 2	O	O	O	O	O	O	O	O	O	O	O
80 / 3	O	O		O	O	O		O	O	O	O
100 / 4	O	O		O	O	O		O	O	O	O
150 / 6	O	O		O	O	O		O	O	O	O
200 / 8	O	O		O	O	O		O	O	O	O
250 / 10	O	O		O	O	O		O			
300 / 12	O	O		O	O	O		O			
350 / 14	O	O		O	O	O		O			
400 / 16	O	O		O	O	O		O			

\*Note 1. RF: Raised face flange, RTJ: Ring joint, SW: Socket weld, BW: Butt weld.  
 Bigger sizes are available, please contact Valmet.

## Packing constructions

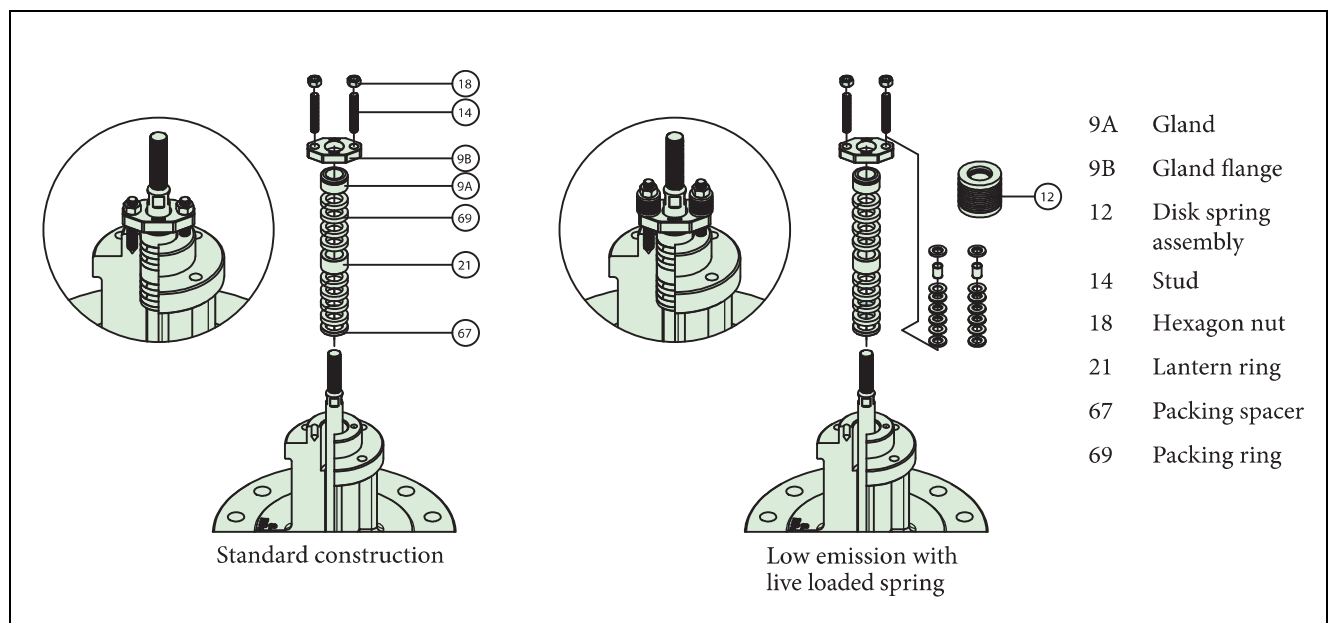

## Rated Cv and trim table (Globe single seat, balanced type, series GB)

Sign	Trim type	Sign	Trim characteristic	Sign	Rated Cv																		
					Description	Body size and stroke																	
						2"	Str.	3"	Str.	4"	Str.	6"	Str.	8"	Str.	10"	Str.	12"	Str.	14"	Str.	16"	Str.
A	General plug	L	Linear	FC	General / Full capacity	74	(40)	142	(50)	230	(50)	380	(60)	600	(70)	950	(80)	1270	(120)	1740	(140)	2215	(160)
A	High temp. balanced plug			1A	General / 1-Step reduction	48	(40)	98	(50)	160	(50)	275	(60)	455	(70)	700	(80)	970	(120)	1300	(140)	1530	(160)
P	Pilot balanced plug			2A	General / 2-Step reduction	26	(40)	56	(50)	86	(50)	150	(60)	254	(70)	398	(80)	550	(120)	776	(140)	940	(160)
				3A	General / 3-Step reduction	16	(40)	34	(50)	52	(50)	90	(60)	152	(70)	238	(80)	340	(120)	464	(140)	568	(160)
				FT	Tendril 1 / Full capacity	52	(40)	102	(50)	160	(50)	290	(60)	460	(70)	630	(80)	980	(120)	1300	(140)	1580	(160)
				1T	Tendril 1 / 1-Step reduction	40	(40)	75	(50)	120	(50)	220	(60)	340	(70)	460	(80)	735	(120)	985	(140)	1145	(160)
				2T	Tendril 1 / 2-Step reduction	27	(40)	40	(50)	70	(50)	130	(60)	195	(70)	255	(80)	405	(120)	565	(140)	670	(160)
				3T	Tendril 1 / 3-Step reduction	10	(40)	21	(50)	46	(50)	75	(60)	105	(70)	140	(80)	240	(120)	310	(140)	415	(160)
				FM	Tendril 2 / Full capacity	50	(40)	100	(50)	155	(50)	280	(60)	425	(70)	590	(80)	920	(120)	1240	(140)	1530	(160)
				1M	Tendril 2 / 1-Step reduction	35	(40)	74	(50)	115	(50)	215	(60)	330	(70)	450	(80)	720	(120)	970	(140)	1130	(160)
				2M	Tendril 2 / 2-Step reduction	23	(40)	33	(50)	65	(50)	120	(60)	190	(70)	240	(80)	380	(120)	550	(140)	640	(160)
				3M	Tendril 2 / 3-Step reduction	8	(40)	18	(50)	38	(50)	67	(60)	100	(70)	130	(80)	220	(120)	290	(140)	390	(160)
		E	Equal %	FC	General / Full capacity	71	(40)	138	(50)	210	(50)	340	(60)	560	(70)	830	(80)	1240	(120)	1650	(140)	2090	(160)
				1A	General / 1-Step reduction	50	(40)	110	(50)	160	(50)	270	(60)	450	(70)	655	(80)	960	(120)	1275	(140)	1680	(160)
				2A	General / 2-Step reduction	24	(40)	50	(50)	82	(50)	136	(60)	236	(70)	374	(80)	524	(120)	746	(140)	854	(160)
				3A	General / 3-Step reduction	14	(40)	32	(50)	50	(50)	82	(60)	142	(70)	224	(80)	314	(120)	446	(140)	512	(160)
				FT	Tendril 1 / Full capacity	50	(40)	82	(50)	135	(50)	235	(60)	370	(70)	500	(80)	840	(120)	1110	(140)	1400	(160)
				1T	Tendril 1 / 1-Step reduction	35	(40)	58	(50)	95	(50)	170	(60)	265	(70)	370	(80)	600	(120)	785	(140)	1020	(160)
				2T	Tendril 1 / 2-Step reduction	20	(40)	35	(50)	58	(50)	100	(60)	170	(70)	225	(80)	355	(120)	480	(140)	600	(160)
				3T	Tendril 1 / 3-Step reduction	10	(40)	20	(50)	32	(50)	58	(60)	105	(70)	125	(80)	205	(120)	290	(140)	350	(160)
				FM	Tendril 2 / Full capacity	47	(40)	74	(50)	130	(50)	230	(60)	330	(70)	470	(80)	770	(120)	1050	(140)	1320	(160)
				1M	Tendril 2 / 1-Step reduction	33	(40)	56	(50)	92	(50)	165	(60)	245	(70)	330	(80)	570	(120)	720	(140)	960	(160)
				2M	Tendril 2 / 2-Step reduction	19	(40)	33	(50)	52	(50)	95	(60)	145	(70)	190	(80)	330	(120)	430	(140)	550	(160)
				3M	Tendril 2 / 3-Step reduction	8	(40)	16	(50)	25	(50)	52	(60)	80	(70)	110	(80)	190	(120)	270	(140)	295	(160)
Y	Special	Y	Special	YY	Special	Please contact sales office for more information																	

## GB Series Cv vs travel Standard trim (Cage)

ASME Class: 150# - 1500#

Size: 2" - 16"

Flow characteristic: linear

Valve travel [%]							10	20	30	40	50	60	70	80	90	100
FL							0.890	0.888	0.885	0.883	0.880	0.878	0.875	0.872	0.870	0.840
Valve size		Orifice diameter			Travel		Rated Cv									
Inch	mm	Sign	Inch	mm	Inch	mm										
2	50	FC	2.5	64.5	1.6	40	4.9	13.9	22.2	30.3	39.5	48.6	57.3	64.7	69.5	74
		1A					3.5	7.6	12.5	17.3	22.4	27.6	33.1	38.5	43.6	48
		2A					2.6	5.2	7.7	10.3	12.9	15.4	18.0	20.6	23.2	26
		3A					1.6	3.2	4.8	6.3	7.9	9.5	11.1	12.7	14.3	16
3	80	FC	3.5	89.0	2.0	50	8.0	22.0	39.0	59.0	75.0	90.0	105.0	119.0	130.0	142
		1A					6.2	16.6	26.9	36.9	46.6	56.8	67.4	78.0	87.8	98
		2A					4.5	11.1	16.6	22.2	27.7	33.3	38.8	44.4	49.9	56
		3A					3.4	6.7	10.1	13.5	16.8	20.2	23.6	26.9	30.3	34
4	100	FC	4.4	111.5	2.0	50	19.3	41.5	74.4	105.3	133.4	164.5	187.6	206.4	219.3	230
		1A					8.0	25.4	43.1	60.4	77.2	93.8	110.7	127.6	143.9	160
		2A					6.0	17.0	25.5	34.1	42.6	51.1	59.6	68.1	76.6	86
		3A					5.2	10.3	15.4	20.6	25.7	30.9	36.0	41.2	46.3	52
6	150	FC	5.3	133.6	2.4	60	23.0	62.0	123.5	181.0	229.1	269.3	315.2	349.9	370.1	380
		1A					12.0	40.9	71.4	101.4	130.6	158.9	186.7	214.7	242.2	275
		2A					9.5	29.7	44.6	59.4	74.3	89.1	104.0	118.8	133.7	150
		3A					8.0	17.8	26.7	35.6	44.6	53.5	62.4	71.3	80.2	90
8	200	FC	6.9	175.5	2.8	70	28.2	94.2	185.6	288.0	377.1	449.1	514.1	571.9	590.0	600
		1A					14.5	52.5	108.0	172.0	232.0	299.0	365.0	417.0	430.0	455
		2A					10.0	45.0	75.4	100.6	125.7	150.9	176.0	201.2	226.3	254
		3A					9.0	30.1	45.1	60.2	75.2	90.3	105.3	120.4	135.4	152
10	250	FC	8.4	214.2	3.1	80	45.9	189.3	329.3	461.8	583.3	689.9	778.5	847.7	897.9	950
		1A					25.0	103.6	183.3	260.7	337.5	414.1	489.4	562.3	631.5	700
		2A					17.0	78.8	118.2	157.6	197.0	236.4	275.8	315.2	354.6	398
		3A					12.0	46.7	70.1	93.5	116.8	140.2	163.6	186.9	210.3	238
12	300	FC	10.4	264.8	4.7	120	93.2	250.0	463.3	660.0	840.0	990.0	1115.0	1205.0	1250.0	1270
		1A					66.7	167.8	276.8	382.9	485.5	586.9	692.1	796.9	893.0	970
		2A					25.0	108.9	163.4	218.0	272.3	326.7	381.2	435.6	490.1	550
		3A					17.0	67.3	101.0	134.6	168.3	202.0	235.6	269.3	302.9	340
14	350	FC	12.4	315.5	5.5	140	127.4	407.5	673.4	915.6	1128.5	1316.5	1474.2	1593.1	1671.4	1740
		1A					91.3	233.3	393.0	548.1	696.8	838.0	976.4	1105.4	1221.2	1300
		2A					52.0	153.7	230.5	307.3	384.1	460.9	537.8	614.6	691.4	776
		3A					27.0	91.9	137.8	183.7	229.7	275.6	321.6	367.5	413.4	464
16	400	FC	14.1	357.7	6.3	160	189.0	497.0	891.8	1248.0	1535.4	1791.5	1950.0	2063.0	2161.6	2215
		1A					101.3	276.5	448.1	615.0	779.1	941.9	1101.6	1255.7	1398.9	1530
		2A					71.0	186.1	279.2	372.2	465.3	558.4	651.4	744.5	837.5	940
		3A					47.0	112.5	168.7	224.9	281.2	337.4	393.6	449.9	506.1	568

**NOTE**

C<sub>v</sub>: Valve flow coefficient

F<sub>L</sub>: Liquid pressure recovery factor

F<sub>C</sub>: Full capacity                      1A: 1-Step reduction

2A: 2-Step reduction                3A: 3-Step reduction

## GB Series Cv vs travel Standard trim (Cage)

ASME Class: 150# - 1500#

Size: 2"-16"

Flow characteristic: EQ-%

Valve travel [%]							10	20	30	40	50	60	70	80	90	100
FL							0.890	0.890	0.890	0.889	0.887	0.885	0.880	0.876	0.871	0.842
Valve size		Orifice diameter			Travel		Rated Cv									
Inch	mm	Sign	Inch	mm	Inch	mm										
2	50	FC	2.5	64.5	1.6	40	2.00	4.00	6.00	9.00	14.00	21.00	33.00	50.00	66.00	71
		1A					1.07	3.28	5.45	7.57	9.75	12.79	17.86	26.28	39.68	50
		2A					0.59	1.19	1.60	2.48	4.57	8.16	12.88	17.74	21.59	24
		3A					0.34	0.70	0.94	1.45	2.67	4.76	7.51	10.35	12.59	14
3	80	FC	3.5	89.0	2.0	50	4.00	8.50	14.50	22.00	33.50	51.00	75.00	108.00	128.00	138
		1A					2.50	3.72	6.61	11.10	18.35	29.43	45.56	67.65	91.99	110
		2A					1.22	2.48	3.34	5.17	9.52	17.00	26.82	36.97	44.98	50
		3A					0.78	1.59	2.14	3.31	6.09	10.88	17.17	23.66	28.79	32
4	100	FC	4.4	111.5	2.0	50	5.60	12.90	23.40	36.90	59.60	86.50	128.20	163.90	188.60	210
		1A					2.75	6.68	11.68	17.92	28.59	46.21	71.85	105.81	141.21	160
		2A					2.00	4.07	5.48	8.48	15.61	27.88	43.99	60.62	73.76	82
		3A					1.22	2.48	3.34	5.17	9.52	17.00	26.82	36.97	44.98	50
6	150	FC	5.3	133.6	2.4	60	6.50	15.00	27.70	47.10	77.10	123.80	198.50	265.20	316.00	340
		1A					3.40	11.12	22.00	32.25	50.35	81.67	126.81	187.40	246.30	270
		2A					3.32	6.76	9.08	14.06	25.89	46.24	72.95	100.54	122.34	136
		3A					2.00	4.07	5.48	8.48	15.61	27.88	43.99	60.62	73.76	82
8	200	FC	6.9	175.5	2.8	70	6.50	23.00	45.00	83.00	138.00	220.00	325.00	445.00	510.00	560
		1A					5.60	19.00	39.00	58.00	94.00	148.00	222.00	310.00	405.00	450
		2A					4.00	11.72	15.76	24.39	44.92	80.23	126.59	174.47	212.29	236
		3A					3.00	7.05	9.48	14.68	27.03	48.27	76.17	104.98	127.73	142
10	250	FC	8.4	214.2	3.1	80	8.10	33.20	65.70	124.40	216.80	350.10	493.20	619.90	747.60	830
		1A					6.52	26.50	47.14	76.22	126.33	219.81	343.21	460.04	566.24	655
		2A					6.13	18.58	24.97	38.66	71.19	127.15	200.62	276.49	336.42	374
		3A					5.47	11.13	14.96	23.15	42.64	76.15	120.16	165.60	201.50	224
12	300	FC	10.4	264.8	4.7	120	22.40	64.30	111.10	179.80	303.10	546.80	795.00	996.00	1155.00	1240
		1A					15.54	44.65	73.67	110.47	174.20	277.57	441.34	650.51	837.52	960
		2A					12.79	26.03	34.99	54.16	99.74	178.14	281.08	387.39	471.35	524
		3A					7.67	15.60	20.97	32.45	59.77	106.75	168.43	232.14	282.45	314
14	350	FC	12.4	315.5	5.5	140	24.70	82.30	158.30	266.70	427.00	693.90	1015.80	1277.20	1514.70	1650
		1A					18.94	60.21	103.15	164.81	260.61	405.54	630.90	903.93	1141.45	1275
		2A					16.21	37.06	49.81	77.10	142.00	253.61	400.17	551.51	671.05	746
		3A					10.89	22.16	29.78	46.10	84.89	151.62	239.24	329.72	401.19	446
16	400	FC	14.1	357.7	6.3	160	35.10	100.40	167.00	268.40	471.00	849.30	1265.10	1603.90	1911.60	2090
		1A					26.32	73.03	119.55	175.70	286.98	477.71	773.09	1125.40	1432.44	1680
		2A					20.85	42.42	57.03	88.27	162.55	290.33	458.10	631.35	768.20	854
		3A					12.50	25.43	34.19	52.92	97.46	174.06	274.65	378.52	460.56	512

NOTE  
 C<sub>v</sub>: Valve flow coefficient  
 F<sub>L</sub>: Liquid pressure recovery factor  
 F<sub>C</sub>: Full capacity  
 2A: 2-Step reduction  
 1A: 1-Step reduction  
 3A: 3-Step reduction.

## GB Series CV vs travel Standard trim (Tendril 1)

ASME Class: 150# - 1500#

Size: 2"-16"

Flow characteristic: linear

Valve travel [%]							10	20	30	40	50	60	70	80	90	100
FL							0.912	0.915	0.917	0.920	0.923	0.926	0.929	0.930	0.925	0.920
Valve size		Orifice diameter			Travel		Rated Cv									
Inch	mm	Sign	Inch	mm	Inch	mm										
2	50	FT	2.5	64.5	1.6	40	3.0	11.8	19.7	26.6	33.2	39.0	43.8	47.7	50.8	52
		1T					1.9	7.7	13.0	17.7	22.4	26.8	31.0	34.8	38.3	40
		2T					1.2	4.8	8.1	11.2	14.3	17.2	20.1	22.8	25.4	27
		3T					0.4	1.7	2.9	4.0	5.2	6.3	7.4	8.5	9.6	10
3	80	FT	3.5	89.0	2.0	50	7.5	23.0	36.9	49.9	61.9	73.2	82.9	91.2	98.0	102
		1T					4.7	14.6	23.7	32.4	40.6	48.8	56.4	63.6	70.4	75
		2T					2.4	7.6	12.4	17.1	21.7	26.2	30.5	34.8	38.9	40
		3T					1.2	3.9	6.4	8.9	11.3	13.8	16.1	18.4	20.7	21
4	100	FT	4.4	111.5	2.0	50	8.5	32.6	55.1	75.9	95.6	113.8	130.5	144.6	156.2	160
		1T					5.3	20.4	34.8	48.3	61.5	74.1	86.7	98.5	109.6	120
		2T					2.9	11.3	19.5	27.3	34.9	42.4	49.9	57.1	64.2	70
		3T					1.9	7.6	13.2	18.5	23.8	28.9	34.2	39.2	44.1	46
6	150	FT	5.3	133.6	2.4	60	13.8	54.4	95.1	134.3	170.9	204.3	234.1	259.9	281.9	290
		1T					9.0	35.2	61.8	88.2	114.1	139.2	163.1	185.7	206.9	220
		2T					4.9	18.9	33.1	47.3	61.6	75.9	90.1	104.1	117.9	130
		3T					2.9	10.8	18.8	26.9	35.0	43.2	51.4	59.5	67.7	75
8	200	FT	6.9	175.5	2.8	70	19.7	87.1	152.3	213.7	271.5	323.2	368.8	409.4	444.2	460
		1T					12.7	56.0	98.8	140.5	181.6	220.5	257.3	292.4	324.9	340
		2T					6.4	28.0	49.5	70.8	92.4	113.6	134.4	155.2	175.5	195
		3T					3.6	15.6	27.5	39.3	51.4	63.3	75.1	87.1	99.0	105
10	250	FT	8.4	214.2	3.1	80	39.7	122.6	206.9	287.7	361.2	430.8	493.5	548.0	597.7	630
		1T					25.7	78.3	132.7	186.4	237.5	288.4	337.1	382.2	426.0	460
		2T					14.2	41.5	69.9	98.4	126.0	154.4	182.4	209.4	236.8	255
		3T					8.4	23.2	38.6	54.1	69.1	84.6	100.2	115.3	130.8	140
12	300	FT	10.4	264.8	4.7	120	76.8	216.1	351.6	478.6	594.1	696.7	786.2	863.1	928.4	980
		1T					48.9	136.8	224.6	310.8	394.0	473.3	548.1	617.8	682.3	735
		2T					25.2	68.8	112.8	156.8	200.8	244.4	287.5	330.0	371.7	405
		3T					15.4	40.7	66.1	91.7	117.4	143.1	168.8	194.5	220.0	240
14	350	FT	12.4	315.5	5.5	140	89.2	275.6	460.6	634.1	789.1	929.1	1050.3	1151.4	1237.4	1300
		1T					56.5	174.0	293.5	410.7	521.9	629.9	731.6	824.7	912.3	985
		2T					29.7	90.1	152.1	214.2	274.8	336.1	396.5	454.9	513.1	565
		3T					16.4	48.4	81.3	114.3	146.8	179.9	212.9	245.3	278.2	310
16	400	FT	14.1	357.7	6.3	160	121.6	332.6	546.9	756.9	949.0	1121.7	1274.6	1402.5	1508.5	1580
		1T					73.6	198.0	326.6	458.4	586.9	712.2	834.3	948.3	1055.2	1145
		2T					41.5	108.3	177.2	248.6	319.8	391.4	464.1	535.3	605.7	670
		3T					26.9	68.0	110.1	153.6	197.1	241.1	286.2	330.8	375.6	415

**NOTE**

C<sub>v</sub>: Valve flow coefficient

F<sub>L</sub>: Liquid pressure recovery factor

F<sub>C</sub>: Full capacity

2A: 2-Step reduction

1A: 1-Step reduction

3A: 3-Step reduction.

## GB, Valve dimensions and weights

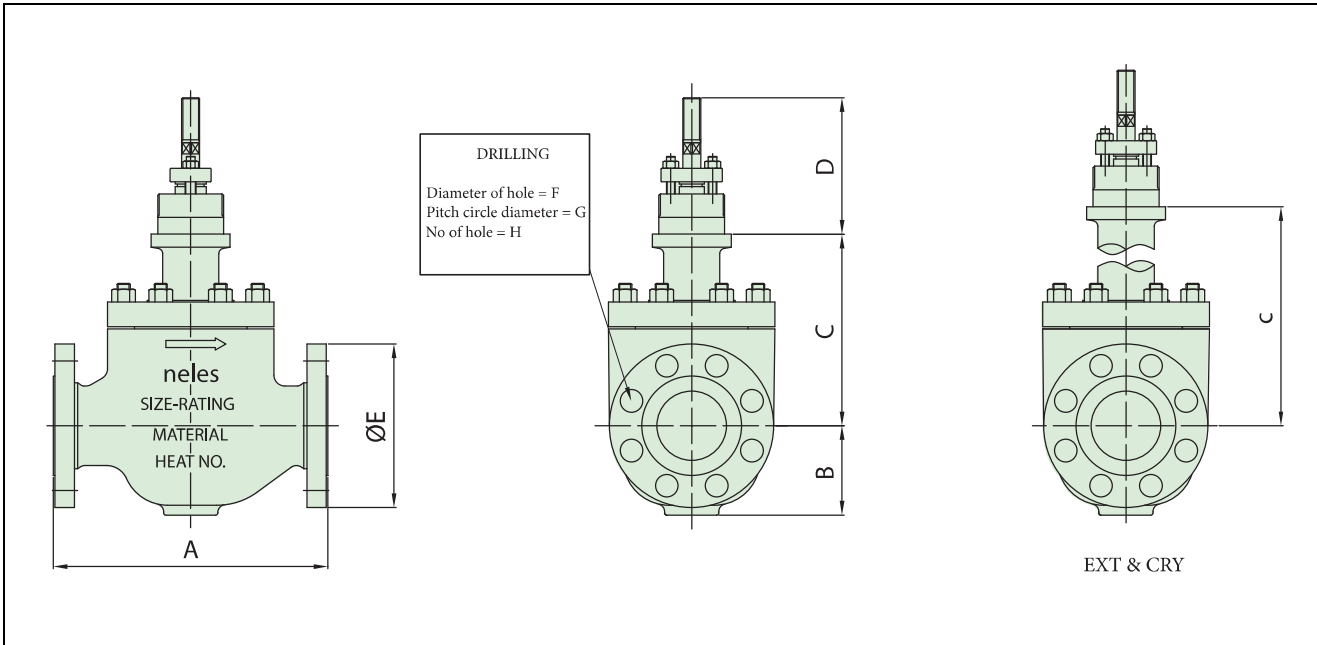

### 150 #/ 300 #/ 600 #

Dimension (mm) Size (mm)	A			B			C			D	E			F			G			H			Weight (kg) (Approximate)		
	150#	300#	600#	150#	300#	600#	STD	EXT	CRY	COMMON	150#	300#	600#	150#	300#	600#	150#	300#	600#	150#	300#	600#	150#	300#	600#
50	254	267	286	83	83	83	178	333	458	110	150	165	165	19.1	19.1	19.1	120.7	127	127	4	8	8	30	32	40
80	298	318	337	109	109	120	222	395	545	115	190	210	210	19.1	22.2	22.2	152.4	168.3	168.3	4	8	8	65	67	72
100	352	368	394	135	135	135	248	402	552	140	230	255	275	19.1	22.2	25.4	190.5	200	215.9	8	8	8	100	103	112
150	451	473	508	170	170	178	340	467	642	150	280	320	355	22.2	22.2	28.6	241.3	269.9	292.1	8	12	12	185	195	240
200	543	568	610	230	230	230	451	557	732	150	345	380	420	22.2	25.4	31.8	298.5	330.2	349.2	8	12	12	363	385	443
250	673	708	752	275	275	275	488	670	870	150	405	445	510	25.4	28.6	34.9	362	387.4	431.8	12	16	16	552	595	681
300	737	775	819	350	350	350	543	716	916	140	485	520	560	25.4	31.8	34.9	431.8	450.8	489	12	16	20	905	955	1020
350	889	927	972	385	385	385	616	846	1046	210	535	585	605	28.6	31.8	38.1	476.3	514.4	527	12	20	20	1170	1230	1311
400	1016	1057	1108	440	440	440	692	909	1109	220	595	650	685	28.6	34.9	41.3	539.8	571.5	603.2	16	20	20	1380	1460	1587

Dimension (inch) Size (inch)	A			B			C			D	E			F			G			H			Weight (lbs) (Approximate)		
	150#	300#	600#	150#	300#	600#	STD	EXT	CRY	COMMON	150#	300#	600#	150#	300#	600#	150#	300#	600#	150#	300#	600#	150#	300#	600#
2"	10	10.5	11.3	3.3	3.3	3.3	7	13.1	18	4.3	5.9	6.5	6.5	0.75	0.75	0.75	4.8	5	5	4	8	8	66	71	88
3"	11.7	12.5	13.3	4.3	4.3	4.7	8.7	15.6	21.5	4.5	7.5	8.3	8.3	0.75	0.87	0.87	6	6.6	6.6	4	8	8	143	148	159
4"	13.9	14.5	15.5	5.3	5.3	5.3	9.8	15.8	21.7	5.5	9.1	10	10.8	0.75	0.87	1	7.5	7.9	8.5	8	8	8	220	227	247
6"	17.8	18.6	20	6.7	6.7	7	13.4	18.4	25.8	5.9	11	12.6	14	0.87	0.87	1.13	9.5	10.6	11.5	8	12	12	408	430	529
8"	21.4	22.4	24	9.1	9.1	9	17.8	21.9	28.8	5.9	13.6	15	16.5	0.87	1	1.25	11.8	13	13.8	8	12	12	800	849	977
10"	26.5	27.9	29.6	10.8	10.8	10.8	19.2	26.4	34.3	5.9	15.9	17.5	20.1	1	1.13	1.37	14.3	15.3	17	12	16	16	1217	1312	1501
12"	29	30.5	32.2	13.8	13.8	13.8	21.4	28.2	36.1	5.9	19.1	20.5	22.1	1	1.25	1.37	17	17.8	19.3	12	16	20	1995	2105	2249
14"	35	36.5	38.2	15.2	15.2	15.2	24.3	33.3	41.2	8.3	21.1	23	23.8	1.13	1.25	1.5	18.8	20.3	20.8	12	20	20	2579	2712	2890
16"	40	41.6	43.6	17.3	17.3	17.3	27.2	35.8	43.7	8.7	23.4	25.6	27	1.13	1.37	1.63	21.3	22.5	23.8	16	20	20	3042	3219	3499

## 900 #/ 1500#

Dimension (mm)	A		B		C		D	E		F		G		H		Weight (kg) (Approximate)	
	900#	1500#	900#	1500#	STD	EXT	COMMON	900#	1500#	900#	1500#	900#	1500#	900#	1500#	900#	1500#
050	375	375	113	113	240	380	110	215	215	25.4	25.4	165.1	165.1	8	8	67	67
080	441	460	142	142	322	430	115	240	265	25.4	31.7	190.5	203.2	8	8	150	163
100	511	530	182	182	376	475	140	290	310	31.8	34.9	235	241.3	8	8	244	255
150	714	768	210	240	420	500	150	380	395	31.8	39	317.5	317.5	12	12	530	540
200	914	972	290	290	550	600	150	470	485	38.1	45	393.7	393.7	12	12	698	821
250	991	1067	310	350	600	700	150	545	585	38.1	51	469.9	482.6	16	12	955	1137
300	1130	1219	385	385	680	800	140	610	675	38.1	54	533.4	571.5	20	16	1180	1240
350	1257	1257	385	385	770	920	210	640	750	41.3	61	558.8	635	20	16	1387	1477
400	1422	1422	450	450	850	1050	220	705	825	44.5	67	616	704.8	20	16	1601	1721

Dimension (inch)	A		B		C		D	E		F		G		H		Weight (lbs) (Approximate)	
	900#	1500#	900#	1500#	STD	EXT	COMMON	900#	1500#	900#	1500#	900#	1500#	900#	1500#	900#	1500#
2"	14.8	14.8	4.5	4.5	9.5	15	4.3	8.5	8.5	1	1	6.5	6.5	8	8	148	148
3"	17.4	18.1	5.6	5.6	12.7	16.9	4.5	9.5	10.4	1	1.25	7.5	8	8	8	331	359
4"	20.1	20.9	7.2	7.2	14.8	18.7	5.5	11.4	12.2	1.25	1.37	9.3	9.5	8	8	538	562
6"	28.1	30.2	8.3	9.5	16.5	19.7	5.9	15	15.6	1.25	1.54	12.5	12.5	12	12	1168	1190
8"	36	38.3	11.4	11.4	21.7	23.6	5.9	18.5	19.1	1.5	1.77	15.5	15.5	12	12	1539	1810
10"	39	42	12.2	13.8	23.6	27.6	5.9	21.5	23	1.5	2.01	18.5	19	16	12	2105	2507
12"	44.5	48	15.2	15.2	26.8	31.5	5.9	24	26.6	1.5	2.13	21	22.5	20	16	2601	2734
14"	49.5	49.5	15.2	15.2	30.3	36.2	8.3	25.2	29.5	1.63	2.4	22	25	20	16	3058	3256
16"	56	56	17.7	17.7	33.5	41.3	8.3	27.8	32.5	1.75	2.64	24.3	27.8	20	16	3530	3794

\*Bigger sizes and higher ratings are available, please contact sales office for more information

## How to order

### Globe balanced, cage guided type, series GB

1.	2.	3.	4.	5.	6.	7.	8.	9.	10.	11.	12.	13.	14.	15.	16.	17.	18.	19.	20.	21.	22.
GB	03	C	W	A	J2	B	P1	X	BC	S1	R1	X	S	G	T	S	G	X	A	E	FC

#### Valve constructions

1.	Valve series	
GB	Globe balanced, cage guided type	

2.	Body size				
02	2"	/ DN 50	03	3"	/ DN 80
04	4"	/ DN 100	06	6"	/ DN 150
08	8"	/ DN 200	10	10"	/ DN 250
12	12"	/ DN 300	14	14"	/ DN 350
16	16"	/ DN 400	18	18"	/ DN 450
20	20"	/ DN 500	24	24"	/ DN 600
YY	Special				

3.	Pressure rating		
C	ASME class 150	D	ASME class 300
F	ASME class 600	G	ASME class 900
H	ASME class 1500	I	ASME Class 2500
J	EN PN 10	K	EN PN 16
L	EN PN 25	M	EN PN 40
N	EN PN 63	P	EN PN 100
B	EN PN 160	E	EN PN 250
Y	EN PN 320	R	JIS 10K
T	JIS 20K		

4.	End connection
W	Flanged RF, ASME B16.5
C	Flanged RF, EN 1092-1
V	Socket welding, ASME B16.11
Q	Butt welding, ASME B16.25
Z	Ring joint flange, ASME B16.5
Y	Special

5.	Bonnet construction	
	Bonnet type	Actuator connection
A	General	Applicable for VD_25/29/37
B	General	Applicable for VD_48/55
C	General	Applicable for VC_30, VB_32
D	General	Applicable for VC/VB_40/50/60/70
E	Extension	Applicable for VD_25/29/37
F	Extension	Applicable for VD_48/55
G	Extension	Applicable for VC_30, VB_32
H	Extension	Applicable for VC/VB_40/50/60/70
P	Cryogenic	Applicable for VD_25/29/37
Q	Cryogenic	Applicable for VD_48/55
R	Cryogenic	Applicable for VC_30, VB_32
S	Cryogenic	Applicable for VC/VB_40/50/60/70
J	Bellows seal	Applicable for VD_25/29/37
K	Bellows seal	Applicable for VD_48/55
L	Bellows seal	Applicable for VC_30, VB_32
M	Bellows seal	Applicable for VC/VB_40/50/60/70
Y	Bellows seal	Special

6.	Body material		
J2	A216 gr. WCB	S6	A351 gr. CF8M
J4	A217 gr. WC6	CG	A217 gr. WC9
S1	A351 gr. CF3M	YY	Special

- Bonnet material is equivalent to body material.  
 \* ASME valve face to face length according to ISA 75.08. EN valve face to face length according to ISA 75.08.  
 \* The body, bonnet, trim materials are subject to change as equivalent depending on detail design.  
 \* See 'Neles Globe Type code Instruction' for further options and explanations.

7.	Model code
B	Model B

#### Trim constructions

8.	Plug material	
	Material	Description
P1	CA15	General for carbon steel valve
T6	CF8M	General for stainless steel valve
P2	CA 40	General for high temp. Cr-Mo valve
S1	CF3M	
YY	Special	

9.	Plug application
X	Not applicable
A	Cobalt based alloy
Y	Special

10.	Stem material	
	Material	Description
BC	630 SS + HCr	General for carbon steel valve
TC	316 SS + HCr	General for stainless steel valve
FC	316L SS + HCr	
VX	XM-19	Special materials

11.	Seat type
S1	Single metal seat
T1	Single soft seat
YY	Special

12.	Seat / cage material		
	Seat	Cage	Cage guide
R1	CA15	CB7Cu-1 + HCr	CB7Cu-1 + HCr
R6	CF8M	CF8M + HCr	CF8M + HCr
P2	CA40	CA40	CA40
R3	CF3M	CF3M + HCr	CF3M + HCr
YY	Special	Special	Special

- CA15 / AISI 410 is general for carbon steel valve.  
 - CF8M / AISI 316 is general for stainless steel valve.

13.	Seat application
X	Not applicable
A	Cobalt based alloy
P	Insert PTFE
Q	Insert PTFE + Cobalt based alloy
Y	Special

## Others

14.	Packing / bellows type
S	General packing
E	Low emission, live loaded
C	Bellows Seal (316L SS, Formed)
Y	Special

17.	Gasket material
S	S/W gasket type, 316L SS + Graphite
L	S/W gasket type, 316L SS + PTFE
H	S/W gasket type, 316L SS + Hi-Graphite
Y	Special

15.	Packing material
G	PTFE + Carbon fiber
F	Graphite
C	PTFE + Carbon fiber (ATEX)
T	PTFE V-Ring
C	PTFE + Carbon fiber (ATEX)
H	Hi-Graphite
Y	Special

18.	Stud / nut material
G	A193 gr. B7M / A194 gr. 2HM
D	A193 gr. B8M / A194 gr. 8M
K	A320 gr. B8M cl. 2 / A194 gr. 8M
H	A193 gr. B16 / A194 gr. 7
E	A453 gr. 660 / A453 gr. 660
Y	Special

16.	Seal ring material
G	PTFE + Graphite
H	PTFE + Graphite + Carbon
M	Graphite
T	PTFE
Y	Special

19.	Options
X	Not applicable
E	Anti-erosion
L	Lub. & Isol. valve
W	Water seal
Y	Special

\* ASME valve face to face length according to ISA 75.08. EN valve face to face length according to ISA 75.08.

\* The body, bonnet, trim materials are subject to change as equivalent depending on detail design.

\* See 'Neles Globe Type code Instruction' for further options and explanations.

\* Round bar material such as AISI 410SS ( for A743 gr. CA 15), AISI 316SS (for A351 gr. CF8M), SUS420J2 (for A743 gr. CA40) and AISI 630SS (for A747 gr. CB7Cu-1) can be used depending on manufacturing process.





**Neles Finland Oy (part of Valmet)**

Vanha Porvoontie 229, 01380 Vantaa, Finland.

Tel. +358 10 417 5000.

[www.valmet.com/flowcontrol](http://www.valmet.com/flowcontrol)

Subject to change without prior notice.

Neles, Neles Easyflow, Jamesbury, Stonel, Valvcon and Flowrox, and certain other trademarks, are either registered trademarks or trademarks of Valmet Oyj or its subsidiaries in the United States and/or in other countries.

For more information [www.neles.com/trademarks](http://www.neles.com/trademarks)

