

Neles™ ceramic ball control valves Series E

Neles series E ceramic ball valve is one of the most erosion resistant control valves available today. It is used in abrasive applications such as lime mud, metal slurries, titanium dioxide and cement production where even stellite surfaces do not last.

Enhanced ceramic material, magnesia partially stabilized zirconia (Mg-PSZ), completely lines the series E flow path.

The properties of Mg-PSZ are superior to the more common ceramics found in other valves, and make it suitable for a wide range of severe service industrial applications.

Metal matrix composite (MMC) materials further expand application range of series E to crystallizing slurry media which require additional toughness for transfer of high torque as well as to services exposing to extreme heat shocks or hot (>+200 °C) aqueous media. MMC lining also enables ATEX compliance.

Valves made of special alloys are available on request.

FEATURES

Resists mechanical and thermal shock

- A transformation toughening process gives Mg-PSZ high strength and exceptional fracture toughness, making it extremely resistant to mechanical shock.
- Superior thermal shock resistance capabilities allow for the use of Mg-PSZ without the need for careful warming and cooling of the piping system. This maintains ceramic integrity and prevents cracking.
- Mg-PSZ is an ideal replacement for ordinary low strength, brittle ceramics.
- Unique metal matrix composites (MMC) offer the best mechanical load bearing capacity in crystallizing and solids handling applications
- This combination of material properties makes the valve also an ideal choice for on-off service in metals processing and autoclave applications.

Total erosion resistance

- A full lining of flow path provides complete wear protection from flange to flange.

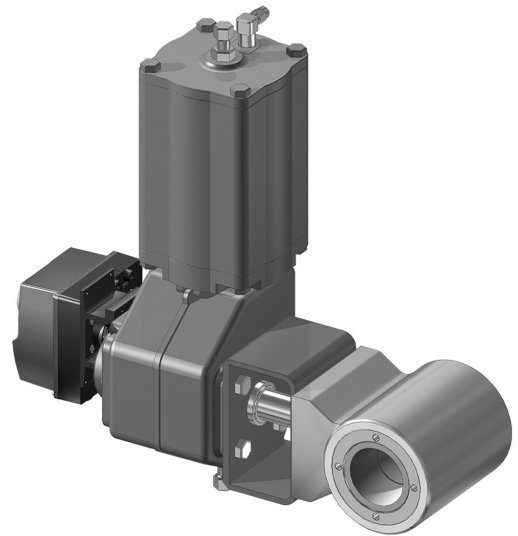

Rigid single piece body

- A single piece body construction is an optimal housing for wear protection lining, as it is robust enough to carry all pressure loads and pipeline forces.

Increased stability and control

- The ball to stem connection is a strong and backlash free, blade joint design.
- The blade joint design eliminates lost angular motion between the ball and stem and provides better control.

Live loaded PTFE packing

- Minimizes fugitive emissions.
- Eliminates the need for frequent packing adjustment.

High strength

The tensile strength (~ 450 MPa) of the special Mg-PSZ is high among ceramics commonly used in industrial practice, and in many aspects comparable to steels.

Exceptional toughness

Due to special transformation toughening features the ceramic material is fracture resistant and not subject to brittleness as traditional ceramics.

Assembly drawing

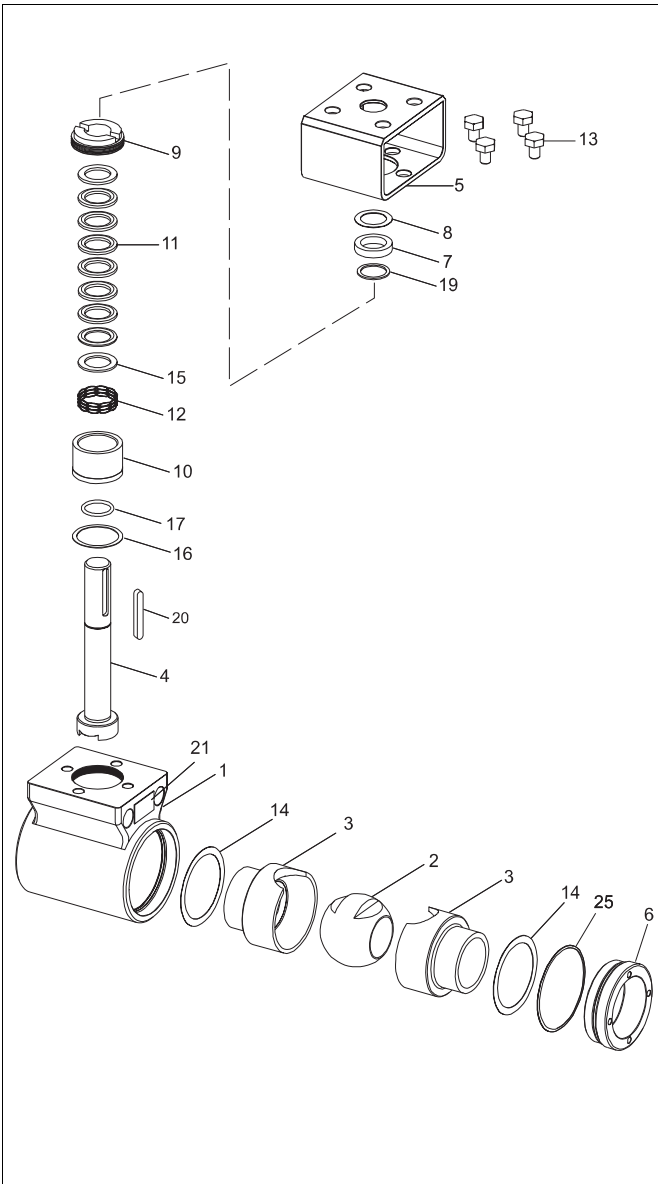

Applications

- lime mud control.
- kaolin, china-clay control.
- carbonate handling.
- gypsum handling.
- cement production.
- metal slurries.
- Autoclave
- catalyst regeneration.
- desulphurization units.

Parts list

Item	Qty	Part description	Material
1	1	Body	Stainless steel, Type AISI 316
2	1	Ball	Zirconia Ceramic, PSZ / MMC / MMC2
3	2	Bushing	Zirconia Ceramic, PSZ / MMC / MMC2
4	1	Shaft	XM-19
5	1	Bracket	Stainless steel, AISI 316
6	1	Clamp ring	Stainless steel, Type AISI 316
7	1	Axial bearing	Stainless steel, AISI 316
8	1	Bearing	PTFE on stainless steel net
9	1	Strain ring	Stainless steel, AISI 316
10	1	Gland bushing	Stainless steel, Type AISI 316
11	1	V-ring set	Polytetrafluoroethylene (PTFE) + C25 % or graphite
12	1	Spiralwave spring	Stainless steel, Type AISI 316
13	4	Hexagon screw	Stainless steel, ISO 3506 A2-70
14	2	Sheet ring	Graphite or PTFE
15	1	Sheet ring	Stainless steel, AISI 316
16	1	Gasket	Graphite
17	1	O-ring	Fluorocarbon rubber (Viton GF)
19	1	Locking ring	Stainless steel,
20	1	Key	SIS 2324
21	1	Identification plate	Stainless steel, AISI 304
25	1	Plate ring	(8" / DN 200 only)

Body styles and end connection

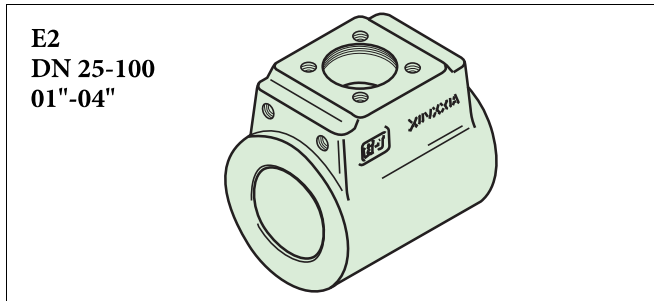

The rigid end-entry type stainless steel body holds the pressure load and pipeline forces protecting the ceramic materials from breakage. The end bushing is screwed to the body enabling easy maintenance.

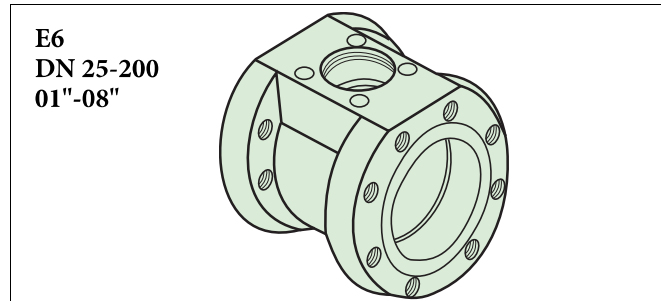

The lug-style body construction allows easier installation of larger size ceramic valves in the pipeline. It also meets the needs of users who prefer more conventional flanged connections while still retaining the advantages of compact size, reduced weight and cost with wafer pattern valves.

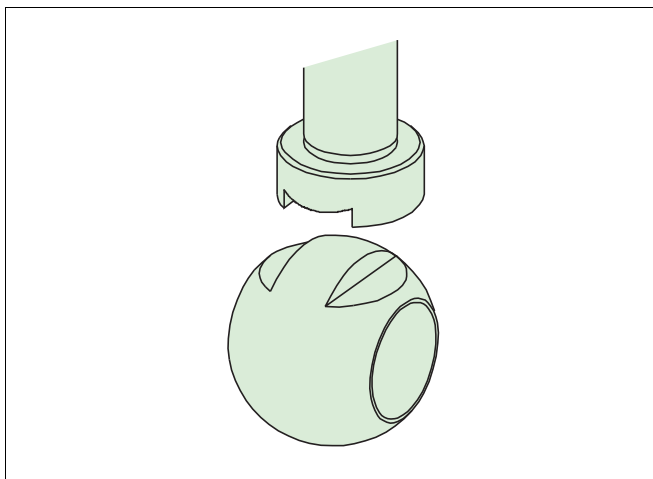

Control stability and strength

The ball to stem joint is a strong and backlash free blade joint which improves control stability.

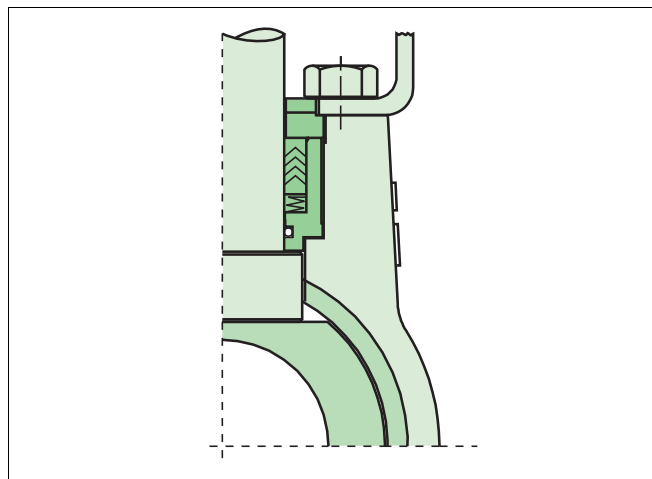

Leakproof packing

The standard design uses a V-ring packing with preloaded spring for continuous tightness eliminating leaks through the packing.

TECHNICAL SPECIFICATIONS

Type:	Reduced bore wafer or lug type ceramic ball valve.
Body:	One-piece, end entry design. Suitable to be fitted between flanges acc. to: ASME 150, 300 PN 10, 16, 25, 40 JIS 10K, 16K, 20K, 30K
Sizes:	DN 25, 40, 50, 80, 100, 150, 200 / NPS 1", 1 1/2", 2", 3", 4", 6", 8"
Face-to-face dimensions:	IEC 534-3-2 / ISA S75.04
Temperature range:	Standard design -50 °C...+200 °C / -40 °F...+390 °F
Valve tightness	
Standard:	ISO 5208, 10 x Rate D (Water).
Option:	ISO 5208, Rate D (Water).
Construction materials	
Body:	Stainless steel CF8M.
Stem:	XM-19.
Ball and bushings:	Zirconia (Mg-PSZ) ceramic as standard. MMC materials as option (M1 and M2).
Gland packing:	PTFE + C25 % V-rings or graphite.

Flow characteristics

Equal percentage.

For ceramic ball valve sizing we recommend our computer (PC) Nelprof™ Selection Software, which is available through www.neles.com/nelprof.

Construction options

Low C_v version (only in DN25/1" size)

When very small flows are to be controlled with high accuracy, the E2-valve is fitted with a special low C_v trim.

The narrow orifice provides an equal percentage flow curve. Excellent choice for additive applications.

C_v-ranges

TypeC05: $C_v = 0 \dots 5$

C15: $C_v = 0 \dots 15$

High temperature version

Graphite packing design with a gland is available for temperatures up to ...+450 °C / +840 °F. This is recommended not only for increased temperatures but also for applications where temperature variations and thermal shocks occur.

ATEX compatibility

A valve with ceramic ball and bushings is not ATEX compatible as a mechanical component for potentially hazardous explosive environment due to the nature of zirconia material. MMC materials (M1, M2) are electrically conductive, and a valve with these trim parts is ATEX compatible. For further information contact Valmet.

Maximum pressure

Maximum body working pressure and differential pressure in shut-off service according to fully rated pressure. Class 300 Maximum pressure difference in throttling service is indicated by line Class 150.

Dimensions

Wafer style body; E2

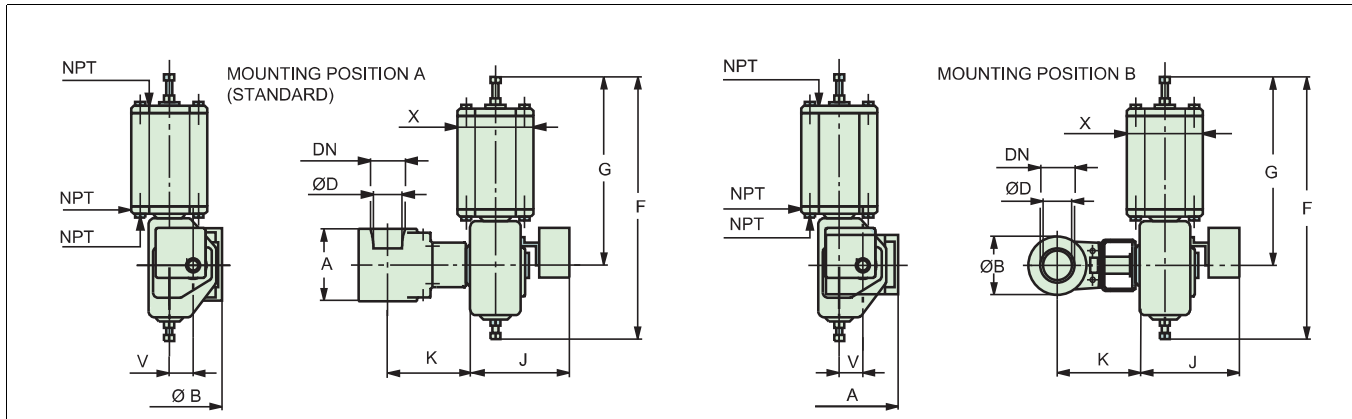

Valve type	Dimensions, mm					Cv 90°	Weight kg
	DN	ø D	A	ø B	K		
E2 025	25	20	102	64	155	61	5
E2 040	40	32	114	82	151	160	7
E2 050	50	40	124	100	160	240	10
E2 080	80	65	165	132	198	640	19
E2 100	100	80	194	157	214	800	30

Actuator type	Dimensions, mm					NPT	Weight t kg
	F	G	J	V	X		
B1C 6	400	260	283	36	90	1/4	9
B1J6, B1JA6	485	368	273	36	110	3/8	13
B1J8, B1JA8	560	420	279	43	135	3/8	22
B1C 6	400	260	283	36	90	1/4	11
B1J6, B1JA6	485	368	273	36	110	3/8	15
B1J8, B1JA8	560	420	279	43	135	3/8	24
B1C 9	455	315	279	43	110	1/4	20
B1J 10	650	490	290	51	175	3/8	40
B1JA 8	560	420	279	43	135	3/8	27
B1C 13	635	445	316	65	175	3/8	50
B1J12, B1JA12	800	620	316	65	215	1/2	76
B1C 13	635	445	316	65	175	3/8	61
B1J16, B1JA16	990	760	351	78	265	1/2	130

Valve type	Dimensions, inch					Cv 90°	Weight lbs
	Size	ø D	A	ø B	K		
E2 01	1	0.80	4.08	2.56	6.20	61	11
E2 1H	1 1/2	1.28	4.56	3.28	6.04	160	15
E2 02	2	1.60	4.96	4.00	6.40	240	22
E2 03	3	2.60	6.60	5.28	7.92	640	41
E2 04	4	3.20	7.76	6.28	8.56	800	65

Actuator type	Dimensions, inch					NPT	Weight lbs
	F	G	J	V	X		
B1C 6	15.75	10.24	11.14	1.42	3.54	1/4	20
B1J6, B1JA6	19.09	14.49	10.75	1.42	4.33	3/8	28
B1J8, B1JA8	22.05	16.54	10.98	1.69	5.31	3/8	48
B1C 6	15.75	10.24	11.14	1.42	3.54	1/4	24
B1J6, B1JA6	19.09	14.49	10.75	1.42	4.33	3/8	33
B1J8, B1JA8	22.05	16.54	10.98	1.69	5.31	3/8	52
B1C 9	17.91	12.40	10.98	1.69	4.33	1/4	44
B1J 10	25.59	19.29	11.42	2.01	6.89	3/8	87
B1JA 8	22.05	16.54	10.98	1.69	5.31	3/8	59
B1C 13	25.00	17.52	12.44	2.56	6.89	3/8	109
B1J12, B1JA12	31.50	24.41	12.44	2.56	8.46	1/2	166
B1C 13	25.00	17.52	12.44	2.56	6.89	3/8	133
B1J16, B1JA16	38.98	29.92	13.82	3.07	10.43	1/2	283

Dimensions

Lug style body; E6

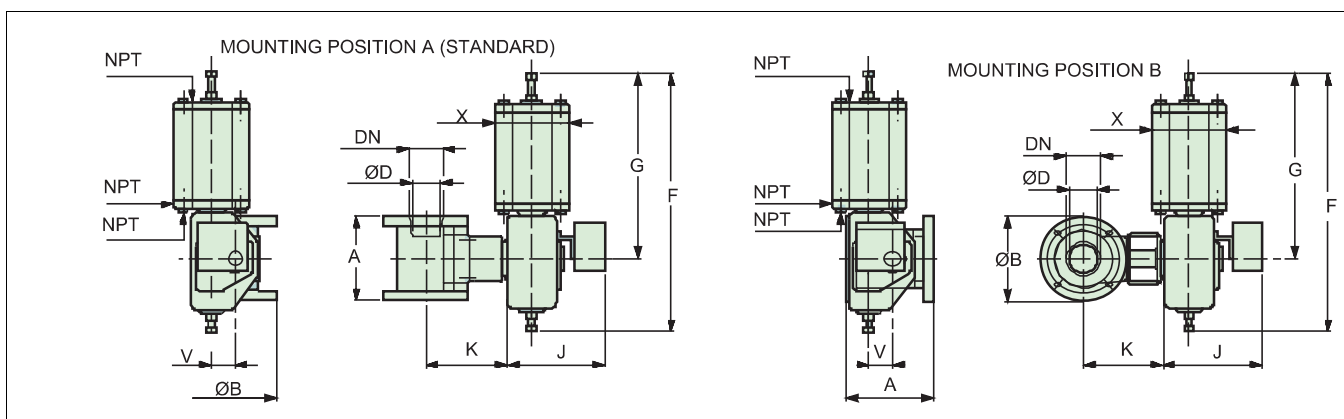

Valve type	Dimensions, mm					Cv 90°	Weight kg	Actuator type	Dimensions, mm					NPT	Weight kg
	DN	ø D	A	ø B	K				F	G	J	V	X		
E6 025	25	20	102	130	155	61	7	B1C 6	400	260	283	36	90	1/4	9
								B1J6, B1JA6	485	368	273	36	110	3/8	13
								B1J 8, B1JA8	560	420	279	43	135	3/8	22
E6 040	40	32	114	160	151	160	11	B1C 6	400	260	283	36	90	1/4	11
								B1J6, B1JA6	485	368	273	36	110	3/8	15
								B1J 8, B1JA8	560	420	279	43	135	3/8	24
E6 050	50	40	124	165	160	240	14	B1C 9	455	315	279	43	110	1/4	20
								B1J 10	650	490	290	51	175	3/8	40
								B1JA 8	560	420	279	43	135	3/8	27
E6 080	80	65	165	210	198	640	27	B1C 13	635	445	316	65	175	3/8	50
								B1J12, B1JA12	800	620	316	65	215	1/2	76
E6 100	100	80	194	254	214	800	45	B1C 13	635	445	316	65	175	3/8	61
								B1J16, B1JA16	990	760	351	78	265	1/2	130
E6 150	150	100	229	325	273	1000	105	B1C 20	840	575	385	97	215	1/2*	178
								B1J20, B1JA20	1200	935	358	97	395	3/4**	280
E6 200	200	135	243	380	300	1550	330	B1C 25/55	1075	725	448	121	265	1/2*	461
								B1J 25/55	1490	1140	448	121	505	3/4**	680
								B1JA 25/55	1490	1140	448	121	505	3/4***	680

Valve type	Dimensions, inch					Cv 90°	Weight lbs	Actuator type	Dimensions, inch					NPT	Weight lbs
	Size	ø D	A	ø B	K				F	G	J	V	X		
E6 01	1	0.79	4.02	5.12	6.10	61	15	B1C 6	15.75	10.24	11.14	1.42	3.54	1/4	20
								B1J6, B1JA6	19.09	14.49	10.75	1.42	4.33	3/8	28
								B1J 8, B1JA8	22.05	16.54	10.98	1.69	5.31	3/8	48
E6 1H	1 1/2	1.26	4.49	6.30	5.94	160	24	B1C 6	15.75	10.24	11.14	1.42	3.54	1/4	24
								B1J6, B1JA6	19.09	14.49	10.75	1.42	4.33	3/8	33
								B1J 8, B1JA8	22.05	16.54	10.98	1.69	5.31	3/8	52
E6 02	2	1.57	4.88	6.50	6.30	240	31	B1C 9	17.91	12.40	10.98	1.69	4.33	1/4	44
								B1J 10	25.59	19.29	11.42	2.01	6.89	3/8	87
								B1JA 8	22.05	16.54	10.98	1.69	5.31	3/8	59
E6 03	3	2.56	6.50	8.27	7.80	640	59	B1C 13	25.00	17.52	12.44	2.56	6.89	3/8	109
								B1J12, B1JA12	31.50	24.41	12.44	2.56	8.46	1/2	166
E6 04	4	3.15	7.64	10.00	8.43	800	98	B1C 13	25.00	17.52	12.44	2.56	6.89	3/8	133
								B1J16, B1JA16	38.98	29.92	13.82	3.07	10.43	1/2	283
E6 06	6	3.94	9.02	12.80	10.75	1000	229	B1C 20	33.07	22.64	15.16	3.82	8.46	1/2*	388
								B1J20, B1JA20	47.24	36.81	14.09	3.82	15.55	3/4**	610
E6 08	8	5.31	9.57	14.96	11.81	1550	719	B1C 25/55	42.32	28.54	17.64	4.76	10.43	1/2*	1005
								B1J 25/55	58.66	44.88	17.64	4.76	19.88	3/4**	1482
								B1JA 25/55	58.66	44.88	17.64	4.76	19.88	3/4***	1482

In the recausticizing process sodium carbonate (Na_2CO_3) is converted into active sodium hydroxide (NaOH). This operation starts with the dissolving of furnace smelt (from the recovery boiler). Weak liquor is applied to form green liquor which is then clarified to remove dregs. Further reaction with lime (CaO) will form white liquor. The white liquor needs clarification in order to

Typical application

Recausticizing

In the recausticizing process sodium carbonate (Na_2CO_3) is converted into active sodium hydroxide (NaOH). This operation starts with the dissolving of furnace smelt (from the recovery boiler).

Weak liquor is applied to form green liquor which is then clarified to remove dregs. Further reaction with lime (CaO) will form white liquor. The white liquor needs clarification in order to eliminate precipitated "lime mud" (CaCO_3) before it is ready for the cooking process.

There are several control valves needed in the described process. Good control of dregs carry over, density, flow rates and temperatures are essential for the complete reaction. The common problem areas of the valves involved are:

- High erosion caused by solids (content up to 40 %), high flow velocity and leakage through the packing seals.
- Jamming of valves caused by high rate of scaling as temperature drops.

In the pressure filtering process the valves must perform certain functions to ensure the automated sequence.

As slaked lime slurry enters the filter, it consists of about 15 ... 20 % solids. In this filtering, the clear white liquor is produced. The flow control of the thick lime mud (40 % solids) needs a very erosion resistant valve (1). The size is typically DN 100 / 4". Also the sequence feed valves (2) require special construction. These are normally DN 400 / 16" butterflies. The lime mud flow control is very demanding because of high erosion. A differential pressure across the valve cannot be avoided.

In this application standard valves survived 2 ... 4 months and valves with stellite surfaces 6 ... 8 months. Neles E2 ceramic valves used in the

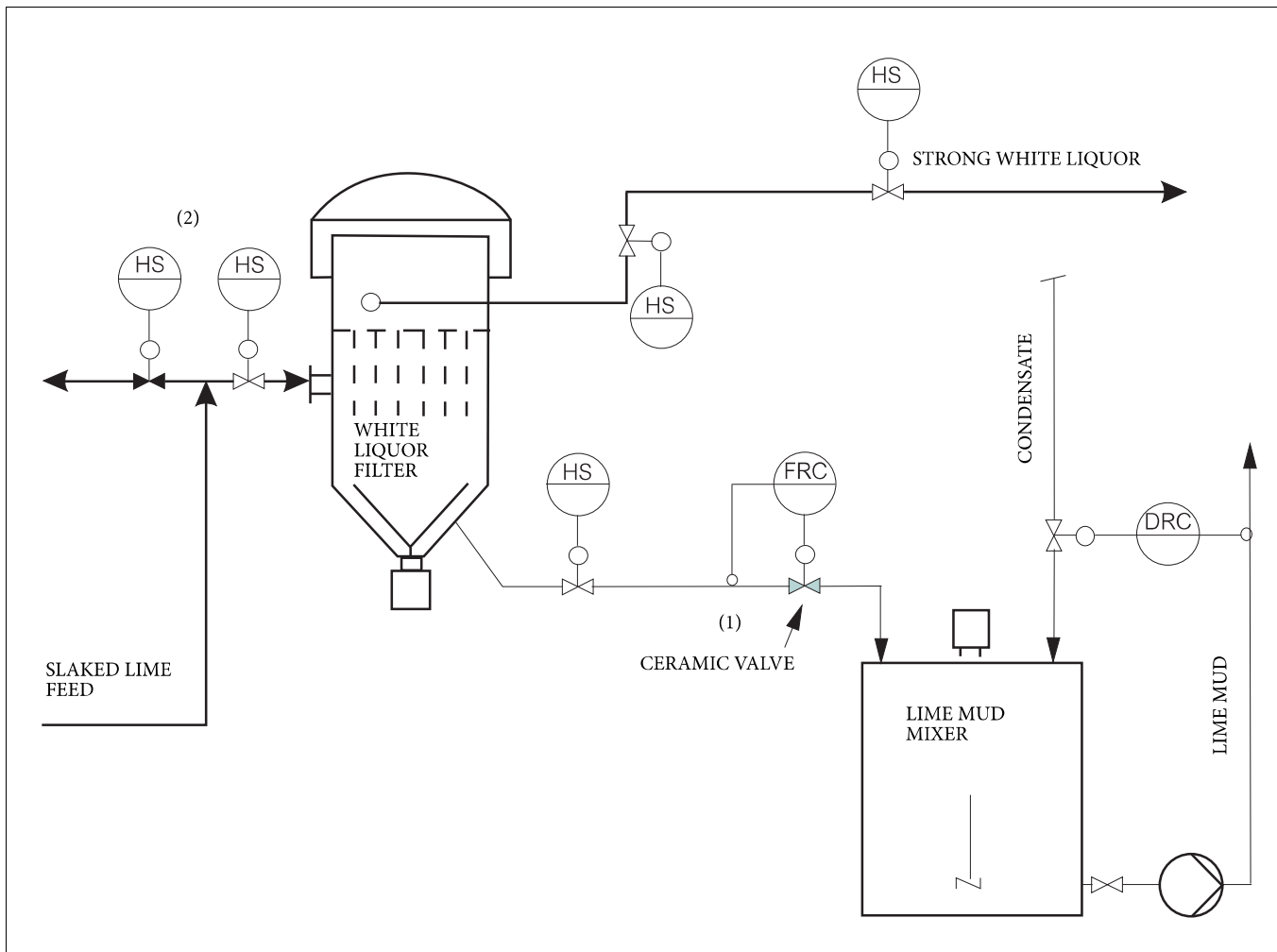

HOW TO ORDER

Example

1	2	3	4	5	6	7
-	E2	L	A	100	X	Z

1	C _v -value of the valve DN 25 / 01"
-	Standard without sign
C05	Maximum C _v 5
C15	Maximum C _v 15

2	Series/ Characteristics
E2	End entry, wafer type, reduced bore, seat supported ball DN 25-100 / 01" - 04"
E6	End entry, lug type, reduced bore, seat supported ball DN 25-200 / 01" - 08"

3	Pressure rating
C	ASME Class 150
D	ASME Class 300
J	PN 10
K	PN 16
L	PN 25
M	PN 40
R	JIS 10 K
S	JIS 16 K
T	JIS 20 K
U	JIS 30 K

4	Construction
A	Standard, V-ring packing, PTFE + C25 %, max temperature +200 °C / +390 °F
H	High temperature, graphite gland packing, max temperature +450 °C / +842 °F

5	Nominal size
	025, 040, 050, 080, 100, 150, 200 01, 1H, 02, 03, 04, 06, 08

6	Metal parts
X	Body: CF8M Shaft: XM-19 Screws: A2-70 Others: 316 SS

7	Wear protection lining materials (Ball, bushings)
Z	Zirconiumoxide, Mg-PSZ
M1	MMC, Composite material for erosion (Atex compatible)
M2	MMC2, Composite material for erosion-corrosion (Atex compatible)

Neles Finland Oy (part of Valmet)

Vanha Porvoontie 229, 01380 Vantaa, Finland.

Tel. +358 10 417 5000.

www.valmet.com/flowcontrol

Subject to change without prior notice.

Neles, Neles Easyflow, Jamesbury, Stonel, Valvcon and Flowrox, and certain other trademarks, are either registered trademarks or trademarks of Valmet Oyj or its subsidiaries in the United States and/or in other countries.

For more information www.neles.com/trademarks

