

Flowrox™ pumps

Transferring LPP-T hose pumps

Flowrox™ LPP-T transfer pumps incorporate an advanced rolling design, which eliminates friction, maximizes hose life and lowers energy consumption. They are ideal for pumping abrasive, corrosive, viscous or crystallizing slurries.

Flowrox LPP-T transfer pumps are equipped with a patented hose flange and reliable inline pipe connections, as well as a hose leak detection unit. Also a patented hose compression adjustment mechanism helps to maximize hose lifetime and minimize the risk of over-compression which leads to 3-5 times longer hose lifetime than conventional hose pumps.



Benefits

- Capability to pump 24/7, no overheating at high continuous flow rates
- Pumps high solid content slurries
- No mixing or shearing
- Energy efficiency
- Low operating costs & ease of maintenance

Ideal applications:

- Thickener underflow
- Tailings
- Filter feed
- Storage tank transfer
- Negative suction lift duties (e.g. sump pumping)

Features

- Advanced single roller design eliminates friction and lowers energy consumption.
- The pump design allows pumping slurries with up to 60-80% solids content.
- Wear resistant hose and connection flanges are the only parts in contact with the medium.
- Low lubrication need, only 20% of that conventional peristaltic pumps use

Technical data	LPP-T32 / LPP-T1.25"	LPP-T40 / LPP-T1.5"	LPP-T50 / LPP-T2"	LPP-T65 / LPP-T2.5"	LPP-T80 / LPP-T3"	LPP-T100 / LPP-T4"
Weight	~360 kg / ~661 lb	~360 kg / ~793 lb	~650 kg / ~1433 lb	~960 kg / ~2166 lb	~2450 kg / ~5401 lb	~4300 kg / ~11684 lb
Flow/revolution	0,87 l / 0.23 gal	1,25 l / 0.33 gal	2,75 l / 0.73 gal	5,4 l / 1.43 gal	11,6 l / 3.06 gal	31,6 l / 8.35 gal
Maximum flow	5,5 m ³ /h / 24.2 gpm	8 m ³ /h / 35.2 gpm	11,5 m ³ /h / 50.6 gpm	20 m ³ /h / 88 gpm	40 m ³ /h / 176 gpm	100 m ³ /h / 440.3 gpm
Maximum pressure	10 bar / 150 psi	10 bar / 150 psi	10 bar / 150 psi	10 bar / 150 psi	7,5 bar / 110 psi	10 bar / 150 psi
Maximum fluid temperature	95 °C / 203 °F (NR-hose: 75 °C / 167 °F)					
Lubricant volume	2,5L / 0.67 gal	2,5L / 0.67 gal	5L / 1.32 gal	5L / 1.32 gal	10L / 2.64 gal	25L / 6.6 gal
Hose bore and flange connection	32 mm / 1.25 in	40 mm / 1.5 in	50 mm / 2 in	65 mm / 2.5 in	80 mm / 3 in	100 mm / 4 in
Motor power	0,75-4 kW / 1-5 hp	1,1-5,5 kW / 1.5-7.5 hp	1,5-9,2 kW / 2-15 hp	3-11,0 kW / 5-15 hp	9,2-22,0 kW / 15-30 hp	37-75 kW / 50-100 hp

Pump curves

LPP-T32 / LPP-T1.25" CAPACITY CHART, CONTINUOUS DUTY, UP TO 95°C / 203°F
(24 h/day/7 days per week)

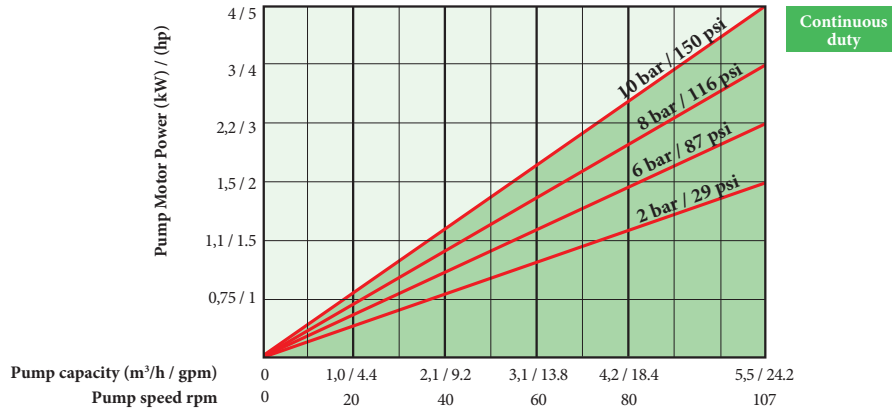

LPP-T40 / LPP-T1.5" CAPACITY CHART, CONTINUOUS DUTY, UP TO 95°C / 203°F
(24 h/day/7 days per week)

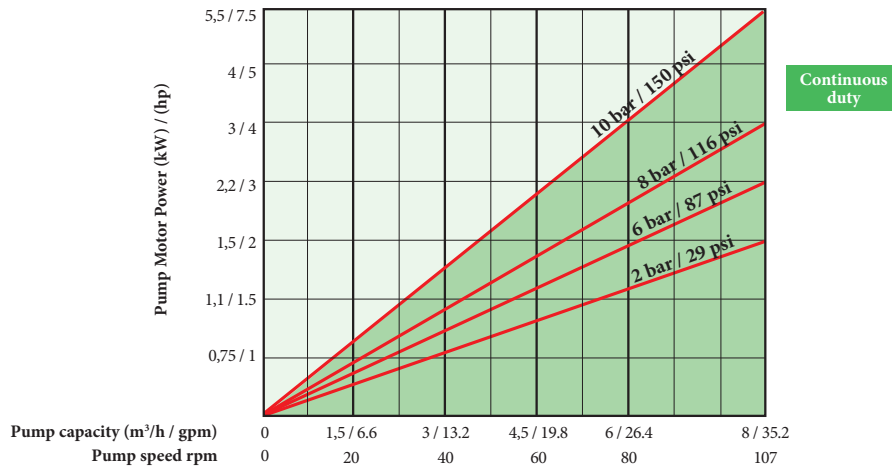

LPP-T50 / LPP-T2" CAPACITY CHART, CONTINUOUS DUTY, UP TO 95°C / 203°F
(24 h/day/7 days per week)

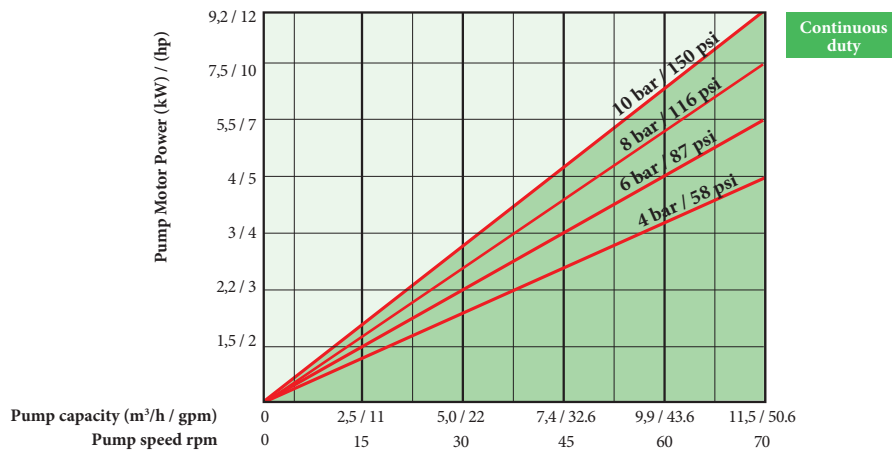

Pump curves

LPP-T65 / LPP-T2.5" CAPACITY CHART, CONTINUOUS DUTY, UP TO 95°C / 203°F
(24 h/day/7 days per week)

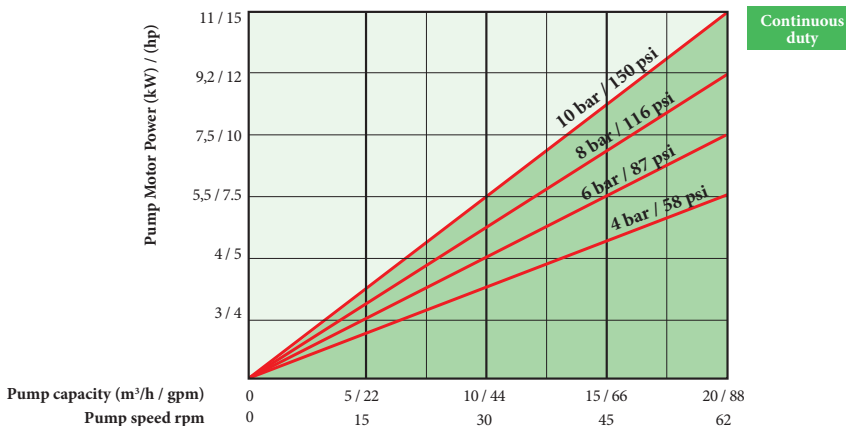

LPP-T80 / LPP-T3" CAPACITY CHART, CONTINUOUS DUTY, UP TO 95°C / 203°F
(24 h/day/7 days per week)

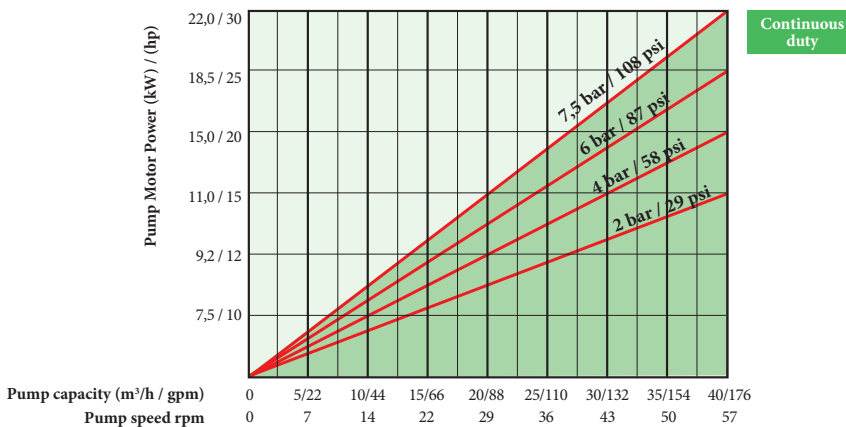

LPP-T100 / LPP-T4" CAPACITY CHART, CONTINUOUS DUTY, UP TO 95°C / 203°F
(24 h/day/7 days per week)

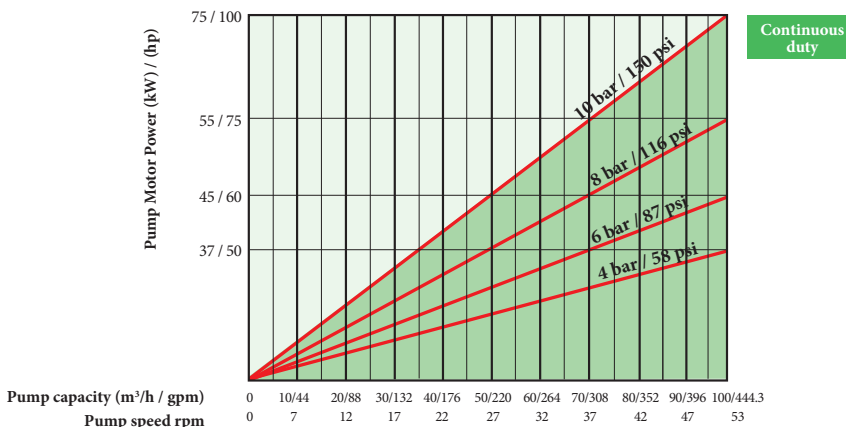

Exploded view of complete LPP-T32 - 80 / 1.25" - 3" pump

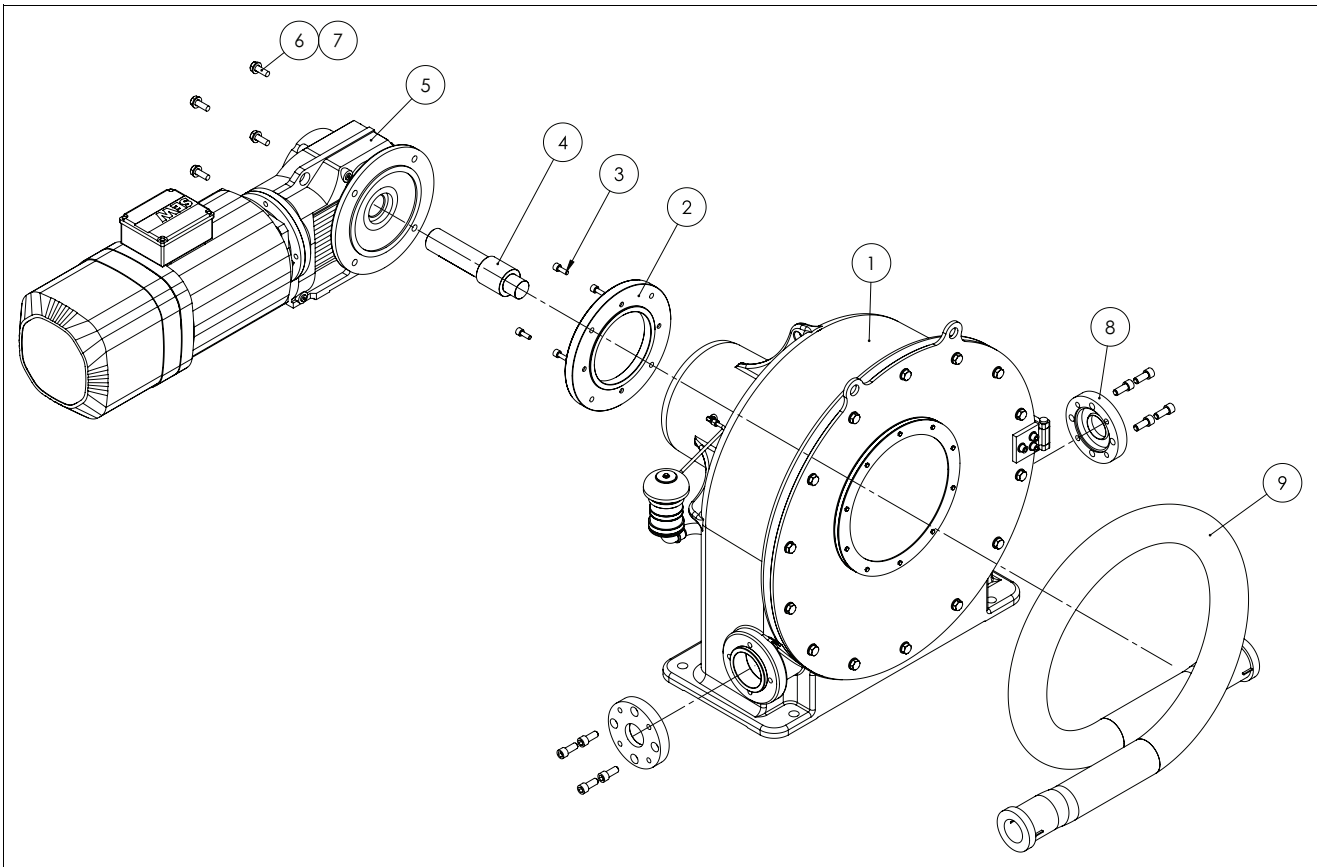

ITEM NO.	DESCRIPTION	QTY.
1	PUMP HEAD	1
2	ADAPTER FLANGE	1
3	SCREW	4
4	DRIVE SHAFT	1
5	GEAR MOTOR	1
6	SCREW	4
7	WASHER	4
8	CONNECTOR FLANGE	2
9	HOSE	1

All exploded parts are modular and order specific. Adapter parts vary depending on the selected gear motor.

Exploded view of LPP-T32 - 80 / 1.25" - 3" pump head

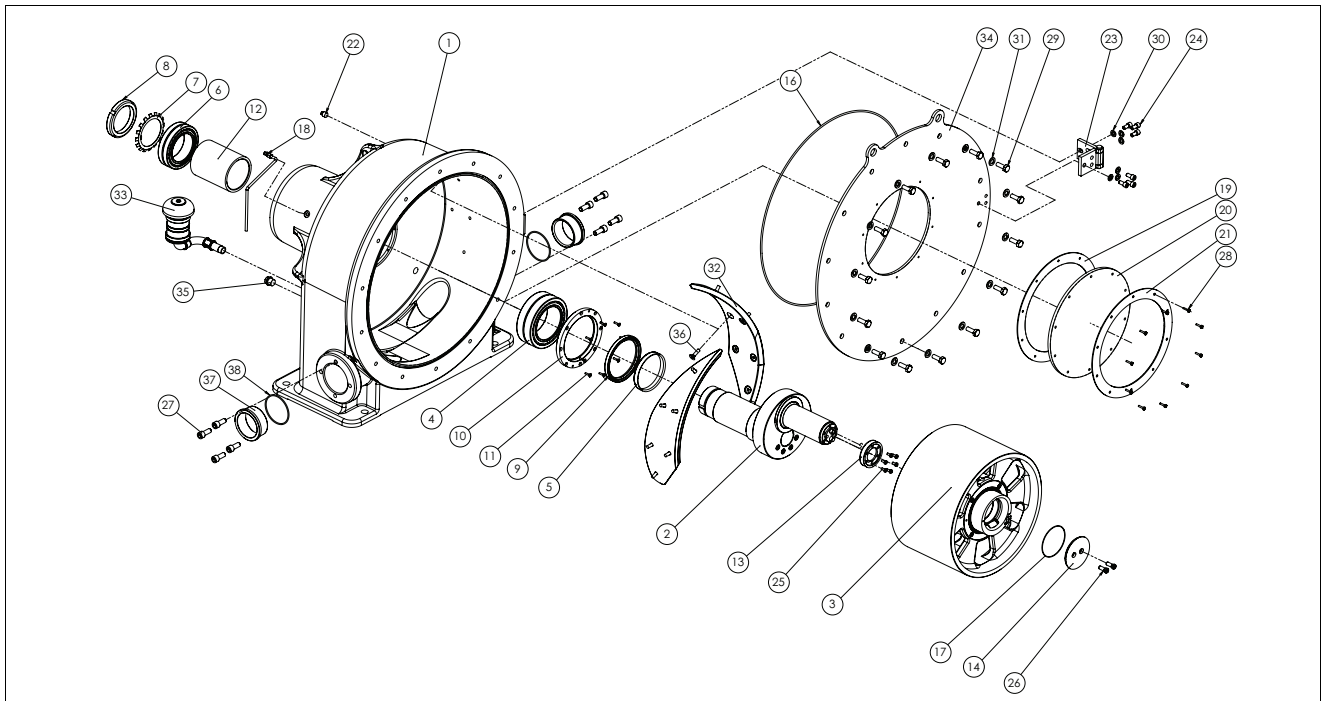

ITEM NO.	DESCRIPTION	QTY
1	BODY	1
2	CRANKSHAFT	1
3	ROTOR ASSEMBLY	1
4	BEARING	1
5	WEAR RING	1
6	BEARING	1
7	LOCK WASHER	1
8	LOCK NUT	1
9	RADIAL SHAFT SEAL	1
10	LOCKING RING	1
11	COUNTERSUNK SCREW	8
12	BUSHING	1
13	GEARED WHEEL	1
14	LOCKING COVER	1
15	GREASE NIPPLE	1
16	O-RING	1
17	O-RING	1
18	CONNECTOR	1
19	WINDOW SEAL	1
20	FRONT WINDOW	1
21	WINDOW PLATE	1
22	PLUG	1
23	HINGE	1
24	HEX SOCKET SCREW	6
25	SOCKET SCREW	6
26	HEX SOCKET SCREW	2
27	HEX SOCKET SCREW	8
28	HEX SCREW	10
29	HEX SCREW	14
30	WASHER	6
31	WASHER	14
32	HOSE GUIDE	2
33	BREATHER SET	1
34	FRONT COVER	1
35	HEX PLUG	2
36	COUNTERSUNK SCREW	12
37	HOSE BUSHING	2
38	O-RING	2

Parts and quantities may vary depending on the pump size.
Hose guides in sizes LPP-T65 & LPP-T80

Exploded view of LPP-T100 / 4" pump

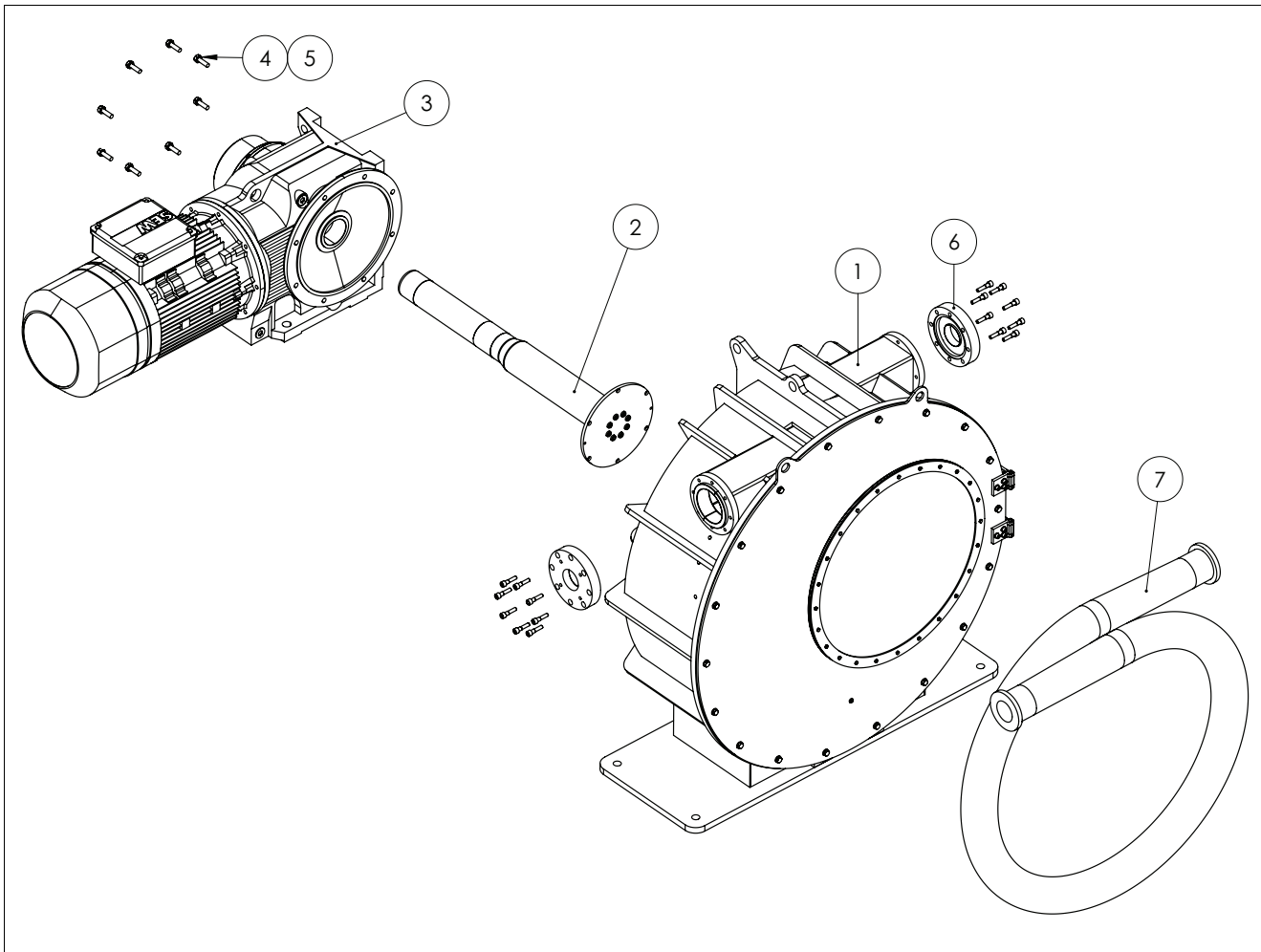

ITEM NO.	DESCRIPTION	QTY.
1	PUMP HEAD	1
2	SHAFT ASSEMBLY	1
3	GEAR MOTOR	1
4	HEX SCREW	8
5	WASHER	8
6	CONNECTOR FLANGE	1
7	HOSE	1

All exploded parts are modular and order specific. Adapter parts vary depending on the selected gear motor.

Exploded view of LPP-T100 / 4" pump head

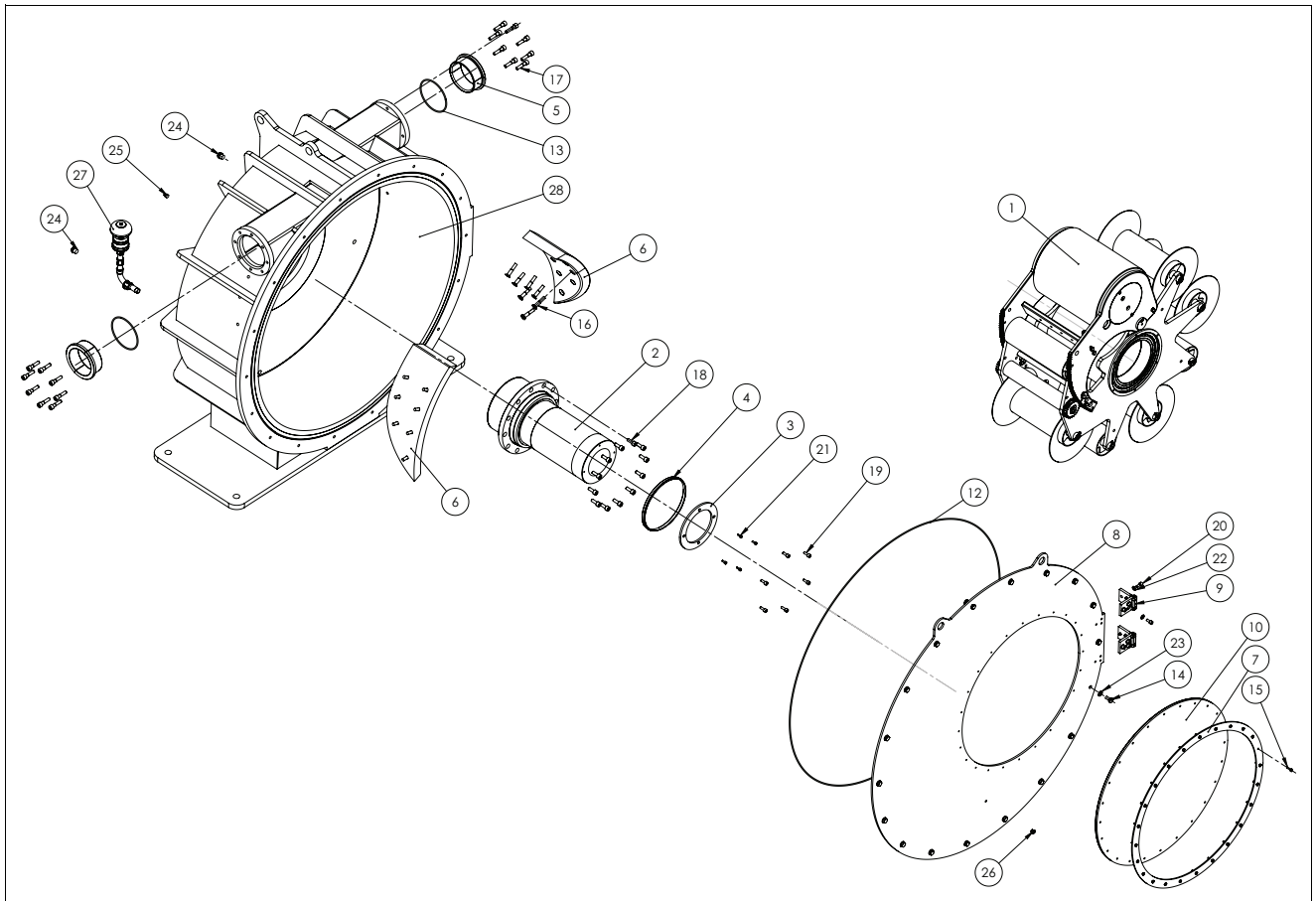

ITEM NO.	DESCRIPTION	QTY
1	ROTOR ASSEMBLY	1
2	CENTER HUB	1
3	FLANGE FOR BEARINGS	1
4	WEAR RING	1
5	BUSHING	1
6	HOSE GUIDE	2
7	SUPPORT FOR WINDOW	1
8	FRONT COVER	1
9	HINGE	2
10	FRONT WINDOW	1
11	WINDOW SEAL	1
12	O-RING	1
13	O-RING	2
14	HEX SCREW	18
15	HEX SCREW	24
16	COUNTERSUNK SCREW	14
17	HEX SOCKET SCREW	16
18	HEX SOCKET SCREW	12
19	HEX SOCKET SCREW	6
20	HEX SOCKET SCREW	12
21	HEX SOCKET SCREW	4
22	WASHER	12
23	WASHER	18
24	HEX PLUG	3
25	PLUG	1
26	PLUG	1
27	BREATHER SET	1
28	BODY	1

Technical specifications

Sizes:

DN 32, 40, 50, 65, 80, 100 / 1.25", 1.5", 2", 2.5", 3", 4"

Connections:

Connection flange drillings: DIN PN10, ANSI 150, BS TABLE D, AS TABLE D/E. Other drillings by request.

Temperature range:

Maximum fluid temperature:

95 °C / 203 °F (NR-hose: 75 °C / 167 °F)

Minimum & maximum ambient operating temperature:

0 to 46 °C / 115 °F

Construction materials:

Body: Nodular cast iron

Rotor: Nodular cast iron

Connection flanges: AISI 316 stainless steel / polypropylene / nylon

Hose material:

- EPDM = Ethylene propylene
- NR = Natural rubber
- NBR = Nitrile
- NBRF = Nitrile (FDA)

Drive unit

- Gear motor
- Gear unit
- Bare shaft

Auxiliaries

- Hose leak detector
- Revolution detector
- Forced cooling fan
- Pressure transmitter
- Frequency inverter

Comparison of Flowrox technology

Flowrox rolling technology is capable of operating in continuous duty with its maximum pressure and maximum flow in the same point. This is where the conventional pump compromises either on pressure or flow.

Compared to Flowrox pumps, conventional hose pumps can only reach less than half of the flow in continuous duty.

What is more, Flowrox pumps can perform even with high temperature media up to 95°C / 203 F.

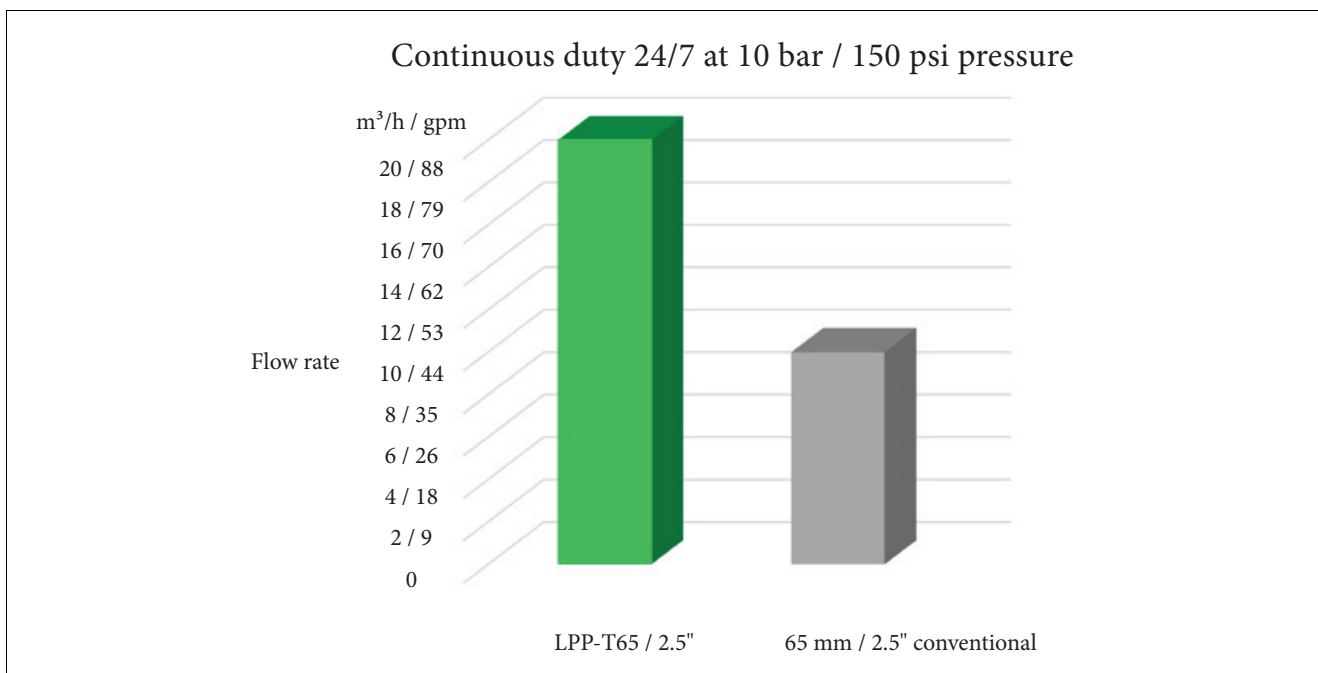
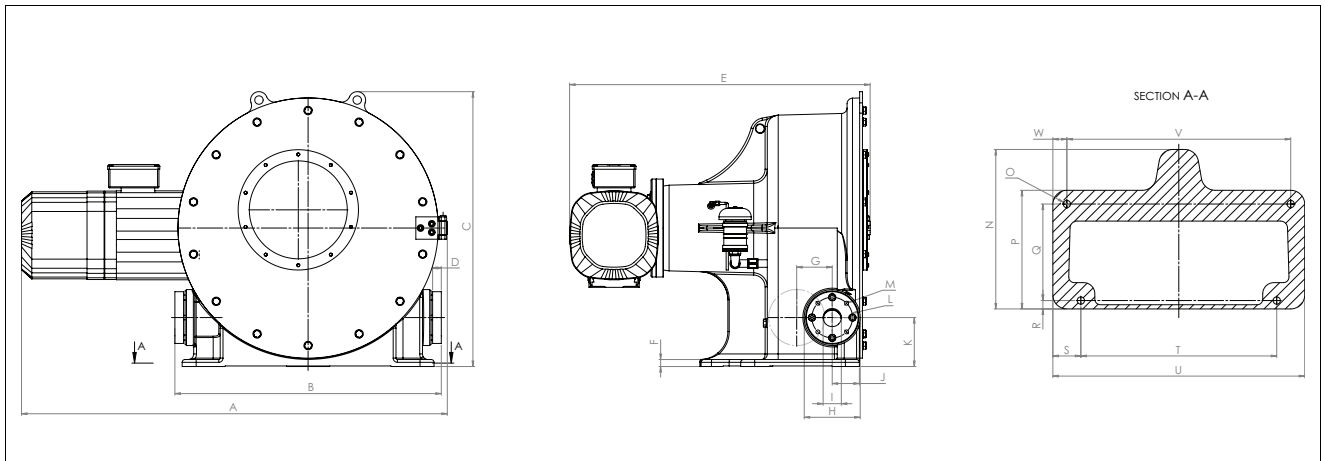

Image: Flowrox hose pump technology vs. conventional technology.

Dimensions, LPP-T32 - 80 / 1.25" - 3" pumps



PUMP MODEL	A	B	C	D	E	F	G	H	I	J	K	L	M	N	O	P	Q	R	S	T	U	V	W
LPP-T32 / 1.25" (gear motor: SEW KF57, 3 kW)	941	652	664	31	724	21	90	150	32	65	130	According to drilling standard	According to drilling standard	394	26	296	220	38	80	440	600	440	80
LPP-T40 / 1.5" (gear motor: SEW KAF67, 5.5 kW)	1070	652	664	31	742	21	90	150	40	65	130	According to drilling standard	According to drilling standard	394	26	296	220	38	80	440	600	440	80
LPP-T50 / 2" (gear motor: SEW KAF87, 9.2 kW)	1381	928	878	45	1023	25	124	200	50	93	188	According to drilling standard	According to drilling standard	526	26	431	290	40	75	700	850	700	75
LPP-T65 / 2.5" (gear motor: SEW KAF87, 11 kW)	1522	952	982	31	1074	25	127	200	65	97	175	According to drilling standard	According to drilling standard	570	26	424	345	30	100	700	900	800	50
LPP-T80 / 3" (gear motor: SEW KAF107, 22kW)	1731	1140	1209	45	1286	35	201	250	80	133	223	According to drilling standard	According to drilling standard	720	26	520	440	40	40	1140	1220	1140	40

Dimensions with the largest available motor size.

Connector flange drillings options: DIN PN10, ANSI 150, BS TABLE D, AS TABLE E/D. Other drillings by request.

Dimensions, LPP-T100 / 4" pump

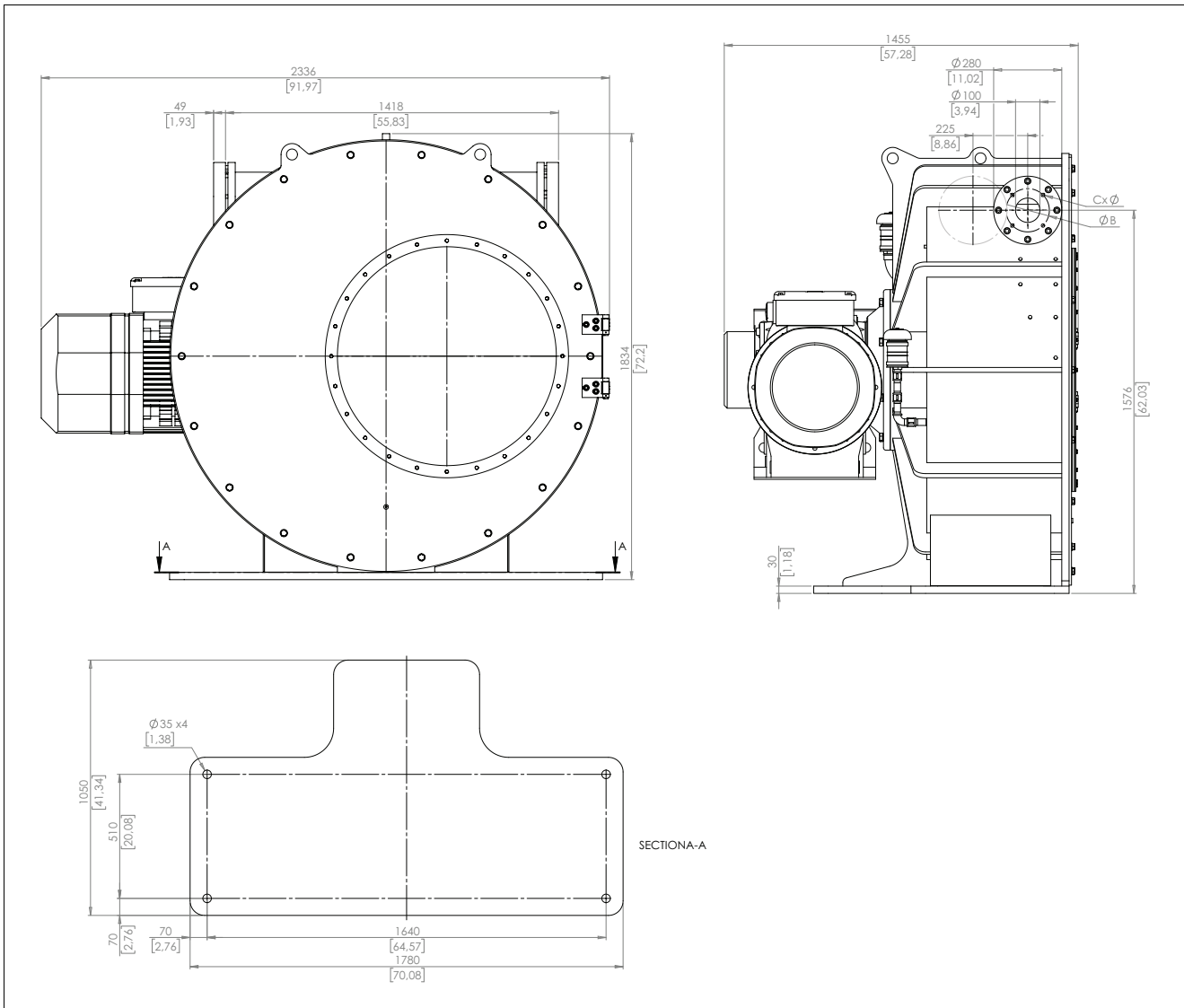

Dimensions with the largest available motor size (SEW KHF157, 75 kW).

Connector flange drillings options: DIN PN10, ANSI 150, BS TABLE D, AS TABLE E/D.

ϕB and $C \times \phi D$ according to drilling standard.

Other drillings by request.

Pump model selection guide

Transfer Pumps LPP-T

1.	2.	3.	4.	5.	6.	7.	8.	9.
LPP-T	65	GM	10	2	0	N	D	NR

1.	TYPE
LPP-T	Transfer

6.	BODY MATERIAL
0	CI/Fe

2.	SIZE (DN)
32	32 mm / 1.25"
40	40 mm / 1.5"
50	50 mm / 2"
65	65 mm / 2.5"
80	80 mm / 3"
100	100 mm / 4"

7.	INVERTER
N	None
II	Wire
Connected IP55	

3.	MOTORIZATION
GM	Gear motor
GU	Gear unit
BS	Bare shaft

8.	AUXILIARIES
D	Hose leak detector
R	Revolution detector
F	Forced cooling fan
T	Pressure transmitter with display
X	Special

4.	PRESSURE CLASS
7,5	7,5 bar / 108 psi*
10	10 bar / 150 psi

9.	HOSE
EPDM	Ethylene propylene diene rubber
NR	Natural rubber
NBR	Nitrile rubber
NBRF	Nitrile rubber (FDA)

* Maximum pressure for the LPP-T80 / LPP-T3 pump is 7,5 bar / 108 psi.

5.	FLANGE DRILLING
1	-
2	DIN PN10
6	ANSI 150
8	BS TABLE D
9A	AS TABLE D
9B	AS TABLE E

Valmet Flow Control Oy

Marssitie 1, 53600 Lappeenranta, Finland.

Tel. +358 10 417 5000.

www.valmet.com/flowcontrol

Subject to change without prior notice.

Neles, Neles Easyflow, Jamesbury, Stonel, Valvcon and Flowrox, and certain other trademarks, are either registered trademarks or trademarks of Valmet Oyj or its subsidiaries in the United States and/or in other countries.

For more information www.neles.com/trademarks

