

UBAN Series

Direct operated pressure reducing valve

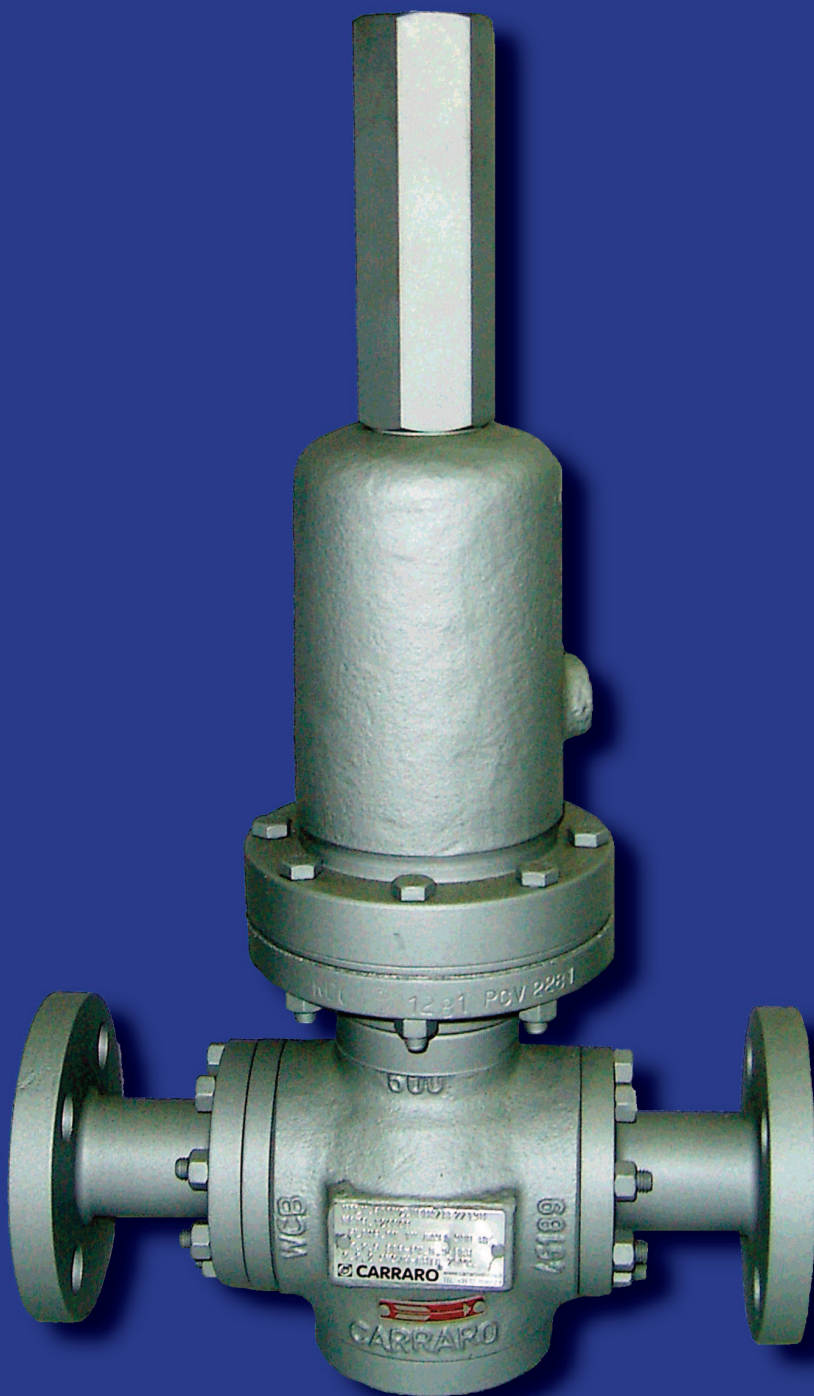

Suitable for:



Air & process gases



Liquids



Steam

Markets:



Oil & gas



Blanketing systems



General industry



Power

Threaded or Flanged Connections Carbon Steel, Stainless Steel & Alloy Construction

Valve ID card

Function
Reducing
Seat type
Single
Inlet / Outlet diameters
From ½" up to 2"
Body material
Carbon steel, Stainless steel and Exotic materials
End connections
Threaded (F-NPT or GAS/BS) and Flanged (ANSI or PN)
Max rating
ANSI 1500
CV
From 0,031 up to 12,8
Trim materials
Stainless steel (std.) and Exotic materials
Diaphragms
Polychloroprene, EPDM, FKM, Stainless steel, other

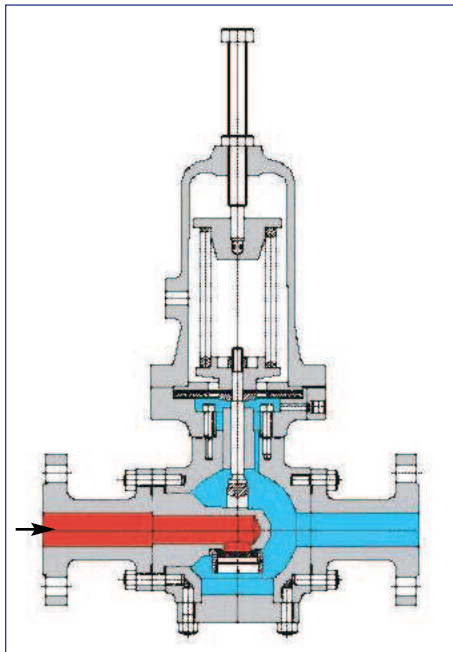

■ Inlet pressure
■ Outlet pressure

Index of tables and specifications

- Fluid applications** • see table 1
- Capacities** • see table 2
- Maximum Inlet Pressure** • see table 3
- Actuators operating range** • see table 4
- Materials of Construction** • see table 5
- Temperature Range** • see tables 6 - 10
- Spring Range** • see table 11
- Weight** • see tables 12 - 15
- Body Sizes and End Connections** • see table 16
- Actuators dimension** • see table 17

The UBAN series are spring loaded direct-operated, pressure reducing regulators.

Their main function is to regulate the outlet pressure. They are available in ½ up to 2 inches (DN15 through DN50) body sizes and can be supplied with a wide range of different end connections. The “bolted” flanged design provides flexibility to meet custom face to face dimensions as required (easy to install / suitable for old valves replacement). These regulators have a compact design and durable construction to sustain rugged use and their construction makes them easy to install and to maintain.

General features:

- Flow to open design
- From 9 to 14 different CV’s for each size to assure high accuracy in regulation
- Metal or Soft Seat (featuring leakage from II to VI, according to Carraro Technical Instruction based on ANSI/FCI 70-3)
- Internal pressure sensing (external on request)
- Packingless construction (available only with internal pressure sensing)
- Different face to face dimensions available (high flexibility in installation)
- Wide range of actuators according to the requested regulation range
- Wide range of elastomeric diaphragms or in AISI 316
- Fully sealed construction available (suitable for dangerous medium; ATEX compliant)
- Balanced construction available for high pressure drops

Special constructions:

- UBAN regulators are also available in special configurations:
- Exotic materials in short lead times (e.g. duplex, superduplex, alloy steel, monel, inconel etc.)
 - Differential versions (with single or double diaphragm) for applications where the differential pressure between two spots has to be controlled and maintained constant
 - HP Body insert for high rating construction (ANSI #900 - #1500)
 - Special welding (BW / SW)

Tab. [1] - Fluid applications

Gas	Air, inert gas, CO ₂ , CO, hydrocarbons, O ₂ , H ₂ , F, NH ₃ , frigorific gas.
Steam	Steam H ₂ O, alcoholic steams, organic steam, sulphuric acid.
Liquids	Water, aqueous solutions, hydrocarbons, alcohol, lubricating oils, diathermic oils, solvents, frigorific fluids, acrylic compounds.

Tab. [2] - Capacities

Nozzle	Body Size									
	½" (DN15)		¾" (DN20)		1" (DN25)		1½" (DN40)		2" (DN50)	
1	0,031	0,031	0,031	0,031	0,031	0,031	0,031	0,031	0,031	0,031
2	0,15	0,11	0,15	0,12	0,16	0,13	0,16	0,15	0,16	0,15
3	0,35	0,24	0,35	0,24	0,35	0,24	0,35	0,24	0,35	0,24
4	0,57	0,40	0,59	0,40	0,59	0,40	0,59	0,40	0,59	0,40
5	1,0	0,44	1,0	0,44	1,0	0,44	1,0	0,44	1,0	0,44
6	1,2	0,67	1,2	0,67	1,2	0,67	1,2	0,67	1,2	0,67
8	2,1	1,2	2,1	1,3	2,2	1,4	2,3	1,4	2,3	1,4
10	3,0	1,7	3,1	1,7	3,1	1,7	3,3	1,9	3,5	1,9
12	4,3	2,0	4,3	2,0	4,4	2,0	4,7	2,0	4,7	2,0
14			5,5	2,4	5,5	2,4	6,0	2,4	6,0	2,4
16			5,9	2,7	6,1	2,7	6,6	2,7	7,9	2,7
18					7,5	3,0	8,2 (8,0*)	3,0	9,2 (9,0*)	3,0
20					8,2	3,5	10,4 (9,8*)	4,0	10,4 (10,1*)	4,0
22							12,8 (12,5*)	4,3	12,8 (12,5*)	4,3

	Cv for all body sizes with elastomer diaphragm
--	---

	Cv for all body sizes with metal diaphragm
--	---

* Reduced Cv for actuator 100

Tab. [3] - Maximum inlet pressures related to temperature

End Connection	Construction	p max				
		RT (20°C/68°F)	100°C (212°F)	200°C (392°F)	250°C (482°F)	300°C (572°F)
Flanged	CS	108 barg (1566 psig)	108 barg (1566 psig)	108 barg (1566 psig)	108 barg (1566 psig)	108 barg (1566 psig)
	Full CS					
	SS					
	Full SS	81 barg (1175 psig)	75 barg (1088 psig)	62 barg (899 psig)	58 barg (841 psig)	54 barg (783 psig)
	Full CS NACE	87 barg (1262 psig)	87 barg (1262 psig)	87 barg (1262 psig)	87 barg (1262 psig)	87 barg (1262 psig)
	SS NACE					
Full SS NACE	73 barg (1059 psig)	62 barg (899 psig)	58 barg (841 psig)	56 barg (812 psig)	55 barg (798 psig)	
Threaded	1/2" through 1"	280 barg (4061 psig)	237 barg (3437 psig)	199 barg (2886 psig)	189 barg (2741 psig)	177 barg (2567 psig)
	1 1/2"	96 barg (1392 psig)	82 barg (1189 psig)	68 barg (986 psig)	64 barg (928 psig)	60 barg (870 psig)

NOTE: CS = Carbon steel, SS = Stainless steel

Tab. [4] - Actuators operating range

Actuators	Actuators spring ranges	Maximum allowable pressure
100	4.5 to 46.0 Barg	52 Barg
120	2.6 to 29.5 Barg	33 Barg
130	1.7 to 22.1 Barg	25 Barg
140	0.7 to 9.2 Barg	10 Barg
220	0,094 to 2,7 Barg	3 Barg
360	0,0025 to 0,84 Barg	1 Barg
515	0,0012 to 0,23 Barg	0,25 Barg

Tab. [5] - Material Combination

Body				
	Carbon steel (AF1/AS1)	Full Carbon steel (AF2/AS2)	316 SS (IF2/IS2)	Full 316 SS (IF3/IS3)
	0°C ≤ T ≤ 200°C (32°F ≤ T ≤ 392°F)	-29°C ≤ T ≤ 300°C (-20°F ≤ T ≤ 392°F)	-29°C ≤ T ≤ 300°C (-20°F ≤ T ≤ 392°F)	-196°C ≤ T ≤ 300°C (-320°F ≤ T ≤ 392°F)
Body	ASME SA-216 WCC	ASME SA-216 WCC	ASME SA-351 CF8M	ASME SA-351 CF8M
HP Insert	ASME SA-351 CF8M	ASME SA-351 CF8M	ASME SA-351 CF8M	ASME SA-351 CF8M
IN/OUT Flanges	ASME SA-216 WCC	ASME SA-216 WCC	ASME SA-216 WCC	ASME SA-216 WCC
Blindhead	ASTM A-350 LF2	ASTM A-350 LF2	ASTM A-479 316	ASTM A-479 316
Studs	ASTM SA-193 B7	ASTM SA-193 B7	EN ISO 3506-1 A4-70	EN ISO 3506-1 A4-70
Nuts	ASME SA-194 2H	ASME SA-194 2H	EN ISO 3506-2 A4-70	EN ISO 3506-2 A4-70
Gaskets set	See Tab. [6]			
Trim				
Disc (standard)	See Tab. [7]			
Plug	ASME SA-351 CF8M	ASME SA-351 CF8M	ASME SA-351 CF8M	ASME SA-351 CF8M
Guide	ASTM 17-4 PH	ASTM 17-4 PH	ASME A-479 304 / NITRONIC 60	ASME A-479 304 / NITRONIC 60
Actuator				
Spring case	ASME SA-278 35	ASME SA-216 WCC	ASME SA-216 WCC	ASME SA-351 CF8M
Actuator diaphragm case	ASME SA-216 WCC	ASME SA-216 WCC	ASME SA-351 CF8M	ASME SA-351 CF8M
Spring	ASTM A-401	ASTM A-401	ASTM A-401	ASTM A-313 316
Diaphragm	See Tab. [8]			

NOTE: SS = Stainless steel

Tab. [6] - Temperature range for flat Gaskets

Materials	Temperature limits
Polytetrafluoroethylene (PTFE)	-200 to 250°C (-328 to 482°F)
No asbestos	-50 to 200°C (-58 to 392°F)
Graphite + AISI 316	-200 to 500°C (-328 to 1022°F)

Tab. [7] - Temperature range and inlet pressure limits for Disc material

Materials	Temperature limits	Maximum pressure
Fluoroelastomer (FKM-FPM)	-10 to 200°C (-14 to 392°F)	40barg (580psig)
Polytetrafluoroethylene (PTFE)	-200 to 250°C (-328 to 482°F)	200barg (2900psig)
Stainless Steel	-196 to 455°C (-321 to 851°F)	280barg (4060psig)

Tab. [8] - Temperature range for Diaphragms

Materials	Temperature limits
Chloroprene (CR)	-20 to 90°C (-4 to 194°F)
NBR	-25 to 90°C (-13 to 194°F)
HNBR	-15 to 120°C (5 to 248°F)
Fluorocarbon (FKM-FPM)	-10 to 200°C (14 to 392°F)
Ethylene-Propylene (EPDM)	-35 to 160°C (-31 to 320°F)
Tetrafluoroethylene/propylene (TFE/P)	5 to 200°C (41 to 392°F)
Silicone (VMQ)	-50 to 150°C (-58 to 300°F)
Fluorosilicone (FVMQ)	-50 to 150°C (-58 to 300°F)
Stainless Steel	-196 to 455°C (-321 to 851°F)

Tab. [9] - Temperature range for O-Rings

Materials	Temperature limits
Polytetrafluoroethylene (PTFE)	-200 to 250°C (-328 to 482°F)
Fluorocarbon (FKM-FPM)	-10 to 200°C (14 to 392°F)

Tab. [10] - Temperature range for Metal parts

Materials	Temperature limits
Cast Iron	0 to 232°C (32 to 449,6°F)
Carbon Steel	-29 to 425°C (-20 to 797°F)
Stainless Steel	-196 to 455°C (-321 to 851°F)



Gauge



Safety device on actuator

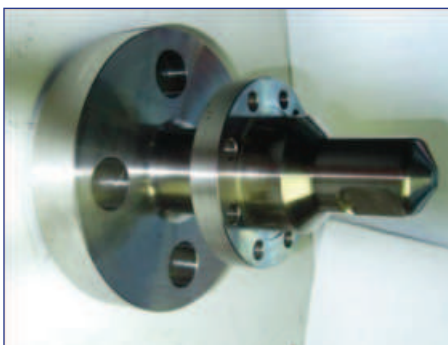

HP Body for high rating construction



Bolts & Nuts PTFE coated

Optionals:

- Bolts & Nuts PTFE coated or other
- Gauge
- Safety device on actuator
- External pressure sensing
- Bug screen

Special configurations:

- Exotic materials
- Differential valves:
 - D1 single Diaphragm
 - D2 double Diaphragm
- Hp body ANSI #900 #1500
- Special weldings:
 - Butt-weld
 - Socket-weld

■ UB REGULATORS

Spring ranges are based on the following assumptions:

- Stroke from setpoint is $\pm 3\text{mm}$
- Offset max 20% for minimum set pressure
- Low unbalancing forces on the plug

If different operating conditions are required please contact Carraro Technical Dept.

* Thin diaphragm (FKM 0,18mm) and upside down installation.

Upright installation

Upsidedown installation

Tab. [11] - Spring ranges

Actuator	Spring	Spring ranges			
		minimum set pressure		maximum set pressure	
		Name	barg	psig	barg
100	4BIS	4,5	65	8,7	126
	6	7,2	105	14,0	203
	7	10,4	151	21,6	314
	8	14,6	211	23,0	334
	9	22,0	319	34,6	502
	9BIS	27,4	397	37,9	550
	10	34,1	494	41,7	604
	10BIS	37,8	548	46,0	667
120	4BIS	2,6	37	4,1	59
	6	3,8	56	6,6	95
	7	5,3	77	10,1	147
	8	7,3	105	10,8	156
	9	10,8	156	16,2	235
	9BIS	13,3	193	17,8	258
	10	16,4	238	19,5	283
130	4BIS	1,7	25	3,0	44
	6	2,7	39	4,9	71
	7	3,8	55	7,6	110
	8	5,2	76	8,0	116
	9	7,8	113	12,1	175
	9BIS	9,7	141	13,2	192
	10	12,0	174	14,5	211
140	4BIS	0,7	10	1,3	19
	6	1,1	16	2,1	31
	7	1,6	23	3,3	47
	8	2,2	32	3,5	50
	9	3,3	48	5,2	75
	9BIS	4,1	60	5,7	83
	10	5,1	74	6,3	91
220	10BIS	5,7	82	9,2	133
	2bis	0,094	1,36	0,12	1,8
	3	0,106	1,54	0,20	3,0
	4	0,127	1,84	0,24	3,4
	4bis	0,144	2,1	0,37	5,4
	6	0,26	3,8	0,60	8,7
	7	0,40	5,8	0,93	13,4
	8	0,58	8,4	0,99	14,3
	9	0,89	13	1,5	21,5
	9bis	1,1	16	1,6	23,6
360	10	1,4	20	1,8	25,9
	10bis	1,6	23	2,7	38,7
	1*	0,0025	0,036	0,014	0,21
	1bis	0,015	0,22	0,018	0,25
	2bis	0,019	0,27	0,039	0,56
	3	0,023	0,33	0,063	0,92
	4	0,029	0,42	0,073	1,1
	4bis	0,035	0,50	0,12	1,7
	6	0,071	1,0	0,19	2,7
	7	0,11	1,6	0,29	4,2
	8	0,17	2,4	0,31	4,4
	9	0,27	3,9	0,46	6,7
515	9bis	0,34	4,9	0,50	7,3
	10	0,43	6,2	0,55	8,0
	10bis	0,48	6,9	0,84	12,2
	1*	0,0012	0,017	0,0077	0,11
	1bis	0,0059	0,09	0,010	0,14
	2bis	0,0080	0,12	0,021	0,30
	3	0,0100	0,15	0,034	0,50
	4	0,014	0,20	0,04	0,6
	4bis	0,016	0,24	0,06	0,9
	6	0,036	0,5	0,10	1,5
7	0,06	0,9	0,16	2,3	
8	0,09	1,3	0,17	2,4	
9	0,14	2,1	0,23	3,3	

Tab. [12] - Weights | Actuators: 100, 120, 130, 140.

	NPT/GAS	Class 150 RF	PN 16/25/40	Class 300 RF	Class 600 RF
DN15 (½")	16,7kg (36,8lbs)	19,6kg (43,2lbs)	20,2kg (44,5lbs)	19,8kg (43,7lbs)	20,1kg (44,3lbs)
DN20 (¾")	16,7kg (36,8lbs)	19,9kg (43,9lbs)	20,8kg (45,9lbs)	20,9kg (46,1lbs)	21,3kg (47lbs)
DN25 (1")	16,6kg (36,6lbs)	20,6kg (45,4lbs)	21,4kg (47,2lbs)	21,5kg (47,4lbs)	21,8kg (48,1lbs)
DN40 (1½")	16,5kg (36,4lbs)	21,6kg (47,6lbs)	22,6kg (49,8lbs)	23,8kg (52,5lbs)	24,8kg (54,7lbs)
DN50 (2")	N.A.	23,1kg (50,9lbs)	24,1kg (53,1lbs)	24,6kg (54,2lbs)	26,1kg (57,5lbs)

Tab. [13] - Weights | Actuator: 220.

	NPT/GAS	Class 150 RF	PN 16/25/40	Class 300 RF	Class 600 RF
DN15 (½")	21,2kg (46,7lbs)	24,1kg (53,1lbs)	20,2kg (44,5lbs)	24,7kg (54,5lbs)	24,6kg (54,2lbs)
DN20 (¾")	21,2kg (46,7lbs)	24,4kg (53,8lbs)	20,8kg (45,9lbs)	25,4kg (56lbs)	25,8kg (56,9lbs)
DN25 (1")	21,1kg (46,5lbs)	25,1kg (55,3lbs)	21,4kg (47,2lbs)	26kg (57,3lbs)	26,3kg (58lbs)
DN40 (1½")	21kg (46,3lbs)	26,1kg (57,5lbs)	22,6kg (49,8lbs)	28,3kg (62,4lbs)	29,3kg (64,6lbs)
DN50 (2")	N.A.	27,6kg (60,9lbs)	24,1kg (53,1lbs)	29,1kg (64,2lbs)	30,6kg (67,5lbs)

Tab. [14] - Weights | Actuator: 360.

	NPT/GAS	Class 150 RF	PN 16/25/40	Class 300 RF	Class 600 RF
DN15 (½")	36,1kg (79,6lbs)	39kg (86lbs)	39,6kg (87,3lbs)	39,2kg (86,4lbs)	39,5kg (87,1lbs)
DN20 (¾")	36,1kg (79,6lbs)	39,3kg (86,6lbs)	40,2kg (88,6lbs)	40,3kg (88,8lbs)	40,7kg (89,7lbs)
DN25 (1")	36kg (79,4lbs)	40kg (88,2lbs)	40,8kg (90lbs)	40,9kg (90,2lbs)	41,2kg (90,8lbs)
DN40 (1½")	35,9kg (79,1lbs)	41kg (90,4lbs)	42kg (92,6lbs)	43,2kg (95,2lbs)	44,2kg (97,4lbs)
DN50 (2")	N.A.	42,5kg (93,7lbs)	43,5kg (95,9lbs)	44kg (97lbs)	45,5kg (100,3lbs)

Tab. [15] - Weights | Actuator: 515.

	NPT/GAS	Class 150 RF	PN 16/25/40	Class 300 RF	Class 600 RF
DN15 (½")	26,4kg (58,2lbs)	29,3kg (64,6lbs)	29,9kg (65,9lbs)	29,5kg (65lbs)	29,8kg (65,7lbs)
DN20 (¾")	26,4kg (58,2lbs)	29,6kg (65,3lbs)	30,5kg (67,2lbs)	30,6kg (67,5lbs)	31kg (68,3lbs)
DN25 (1")	26,3kg (58lbs)	30,3kg (66,8lbs)	31,1kg (68,6lbs)	31,2kg (68,8lbs)	31,5kg (69,4lbs)
DN40 (1½")	26,2kg (57,8lbs)	31,3kg (69lbs)	32,3kg (71,2lbs)	33,5kg (73,9lbs)	34,5kg (76,1lbs)
DN50 (2")	N.A.	32,8kg (72,3lbs)	33,8kg (74,5lbs)	34,3kg (75,6lbs)	35,8kg (78,9lbs)

■ UB REGULATORS

Parts list:

- 1 - Body cover
- 2 - Gaskets set (*)
- 3 - Valve body
- 4 - HP body (seat)
- 5 - Flange
- 6 - Plug
- 7 - Lower diaphragm case
- 8 - Diaphragm (*)
- 9 - Lower diaphragm sealing plate
- 10 - Diaphragm plate
- 11 - O'ring gasket (*)
- 12 - Spring
- 13 - Spring case
- 14 - Upper diaphragm case
- 15 - Screws
- 16 - Adjusting screw locknut
- 17 - Adjusting screw
- 18 - Upper spring washer
- 19 - Lower spring washer
- 20 - Plug locknut
- 21 - Screws
- 22 - Nuts
- 23 - Plug guide bushing
- 24 - Screws
- 25 - Plug disc (*)
- 26 - Studs
- 27 - Nuts
- 28 - Plug screw (*)
- 29 - Ball
- 30 - Cap
- 31 - Pin

UBAN flanged valve section drawing

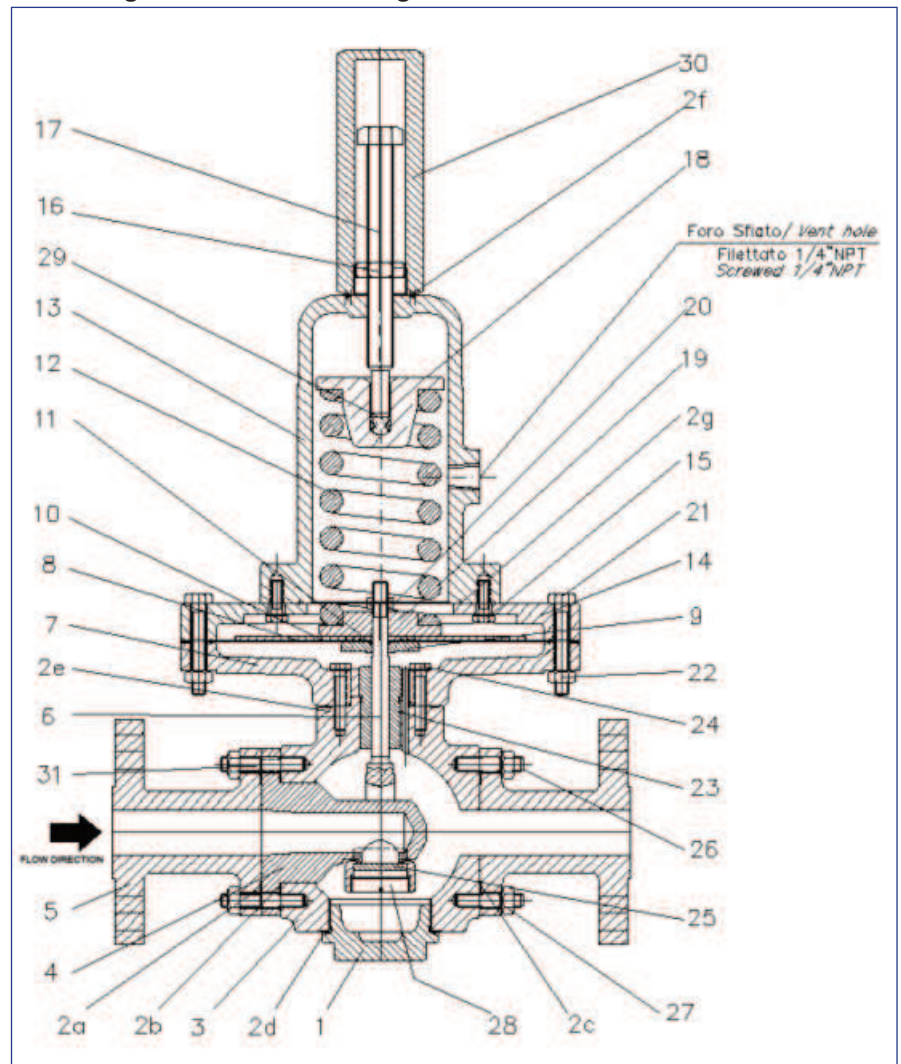

(*) Recommended spare parts

2 Years spare part kit:

- Gasket Kit (3 pcs if threaded - 5 if flang.)
- Plug disc
- Diaphragm kit (Diaphragm + o-ring)

5 Years spare part kit:

- Gasket Kit (3 pcs if threaded - 5 if flang.)
- Plug
- Plug disc
- Diaphragm kit (Diaphragm + o-ring)

2 years spare parts kit for flanged UBAN



2 years spare parts kit for threaded UBAN

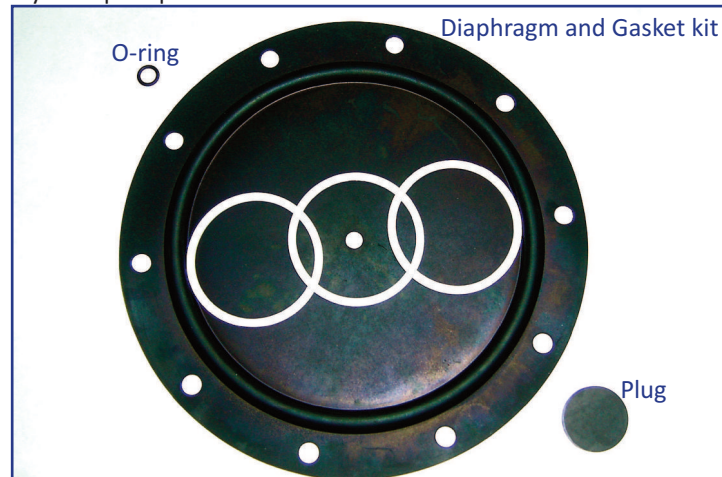

UBAN threaded valve section drawing

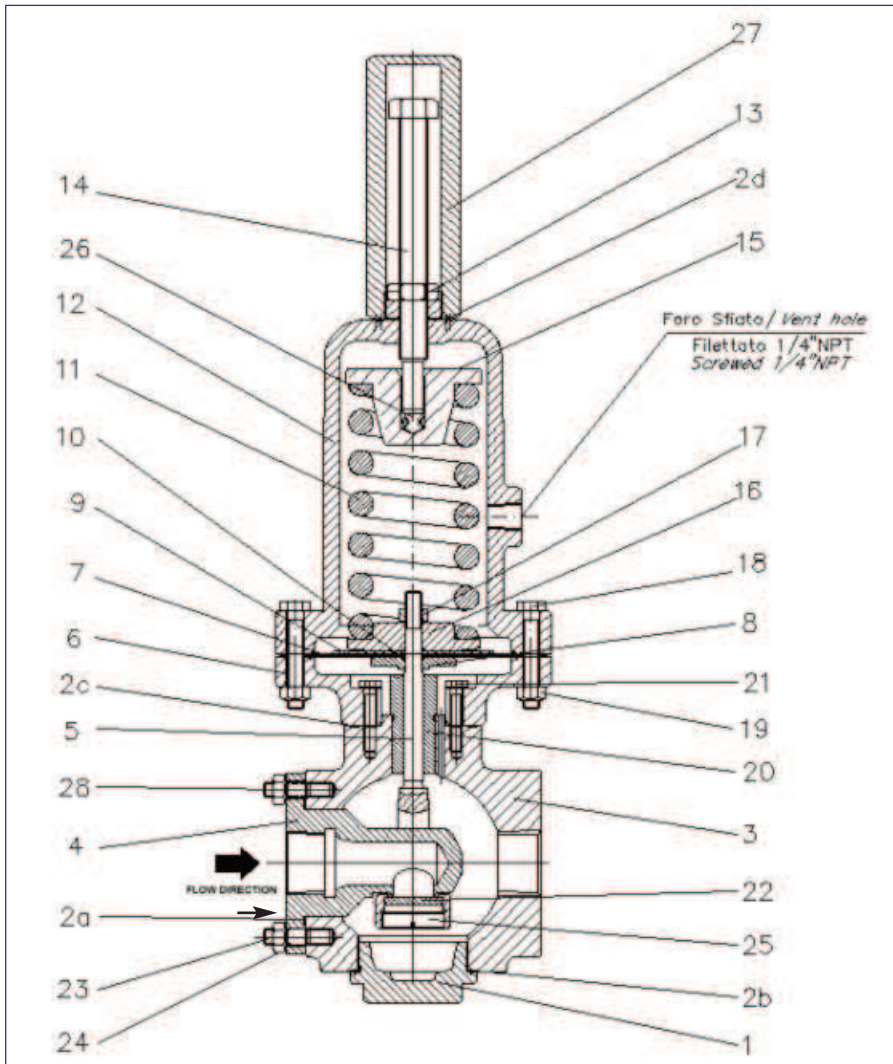

Parts list:

- 1 - Body cover
- 2 - Gaskets set (*)
- 3 - Valve body
- 4 - HP body (seat)
- 5 - Plug
- 6 - Lower diaphragm case
- 7 - Diaphragm (*)
- 8 - Lower diaphragm sealing plate
- 9 - Diaphragm plate
- 10- O'ring gasket (*)
- 11- Spring
- 12- Spring case
- 13- Adjusting screw locknut
- 14- Adjusting screw
- 15- Upper spring washer
- 16- Lower spring washer
- 17- Plug locknut
- 18- Screws
- 19- Nuts
- 20- Plug guide bushing
- 21- Screws
- 22- Plug disc (*)
- 23- Studs
- 24- Nuts
- 25- Plug screw (*)
- 26- Ball
- 27- Cap
- 28- Pin
- 29- Balanced plug spring washer
- 30- Ball
- 31- Spring

(*) Recommended spare parts

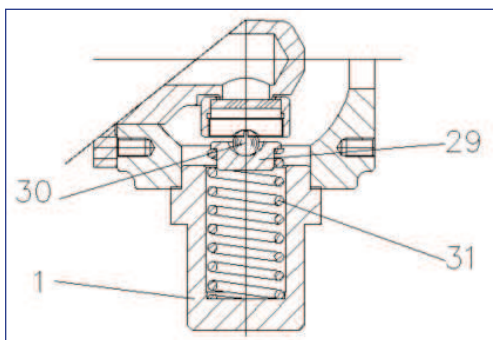

Balanced plug construction

This device is used with very low set pressure to balance the system in case of high pressure drop and oversized nozzle.

Threaded UBAN



UBAN flanged valve dimensional drawing

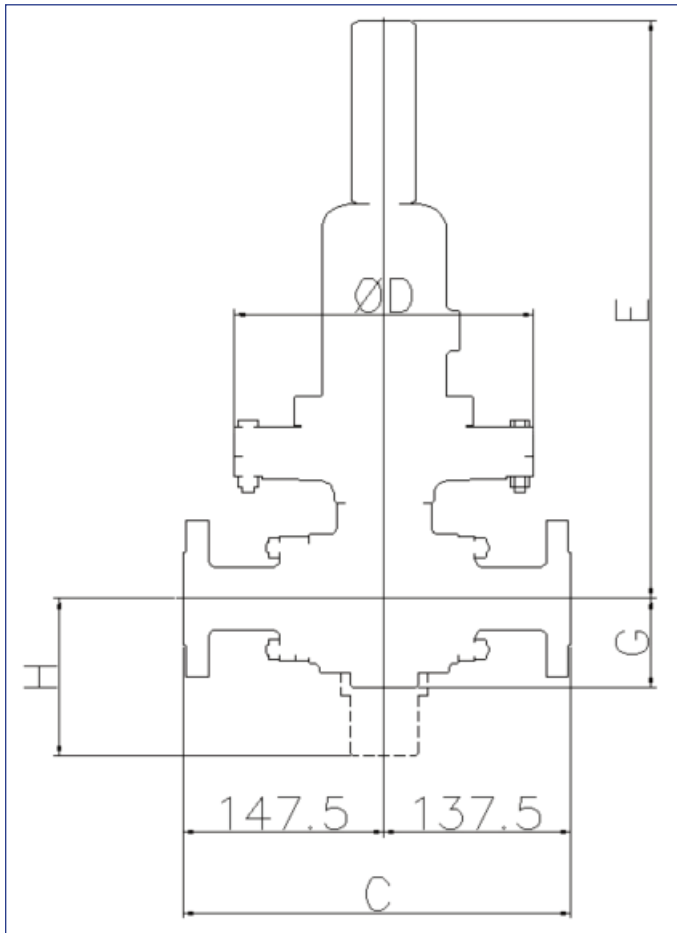

UBAN threaded valve dimensional drawing

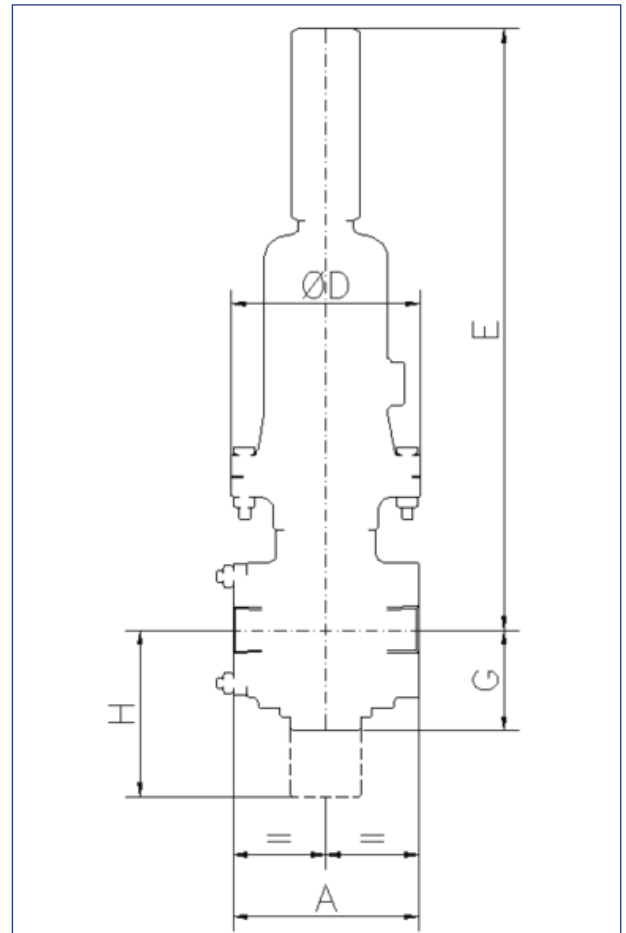

Tab. [16] - Body sizes and face to face dimensions

Size (DN)	Flanged				Threaded			
	PN 16				NPT-F			
	PN 25				GAS-F Con.			
	PN 40				BSP-F			
	ANSI 150RF							
	ANSI 300RF							
	ANSI 600RF							
	C	E	G	H	A	E	G	H
½" (DN15)	285mm (11 ¼")	431mm (17")	80mm (3,15")	115mm (4 ½")	130mm (5 ⅛")	430mm (17")	80mm (3 ⅞")	115mm (4 ½")
¾" (DN20)								
1" (DN25)								
1½" (DN40)								
2" (DN50)								

Tab. [17] - Actuators dimension (quote D)

Actuator	Outer diameter	Surface
	mm	cm ² (in ²)
100	132	9,7 (1,5)
120	132	20,7 (3,2)
130	132	27,8 (4,3)
140	140	64,5 (10)
220	220	226,5 (35,1)
360	360	730,1 (113,2)
515	480	1346 (208,6)

Actuator 100/120

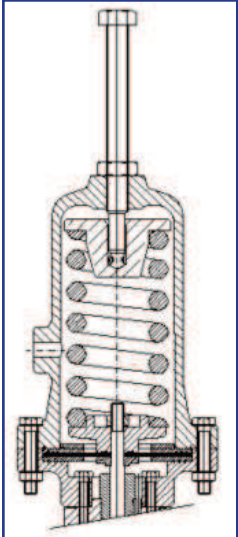

Actuator 130

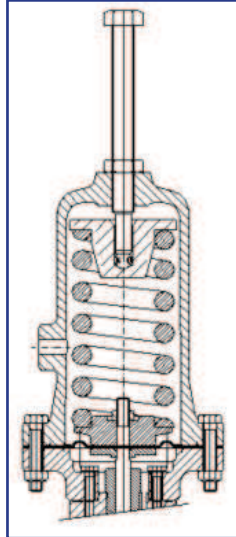

Actuator 140

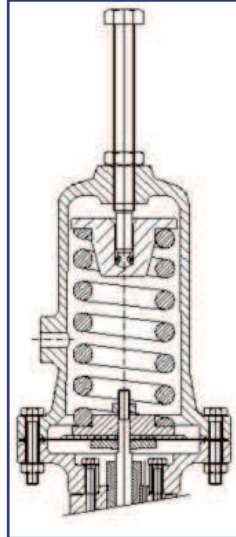

Actuator 220

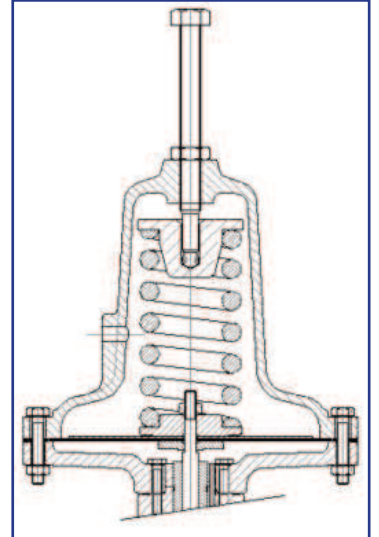

Actuator 360

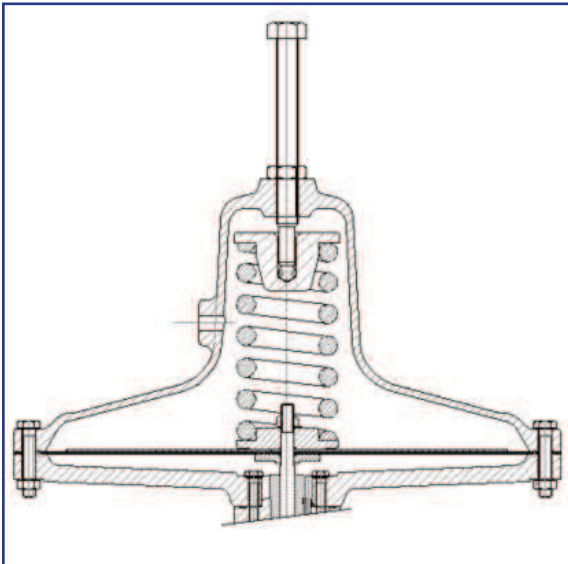

Actuator 515

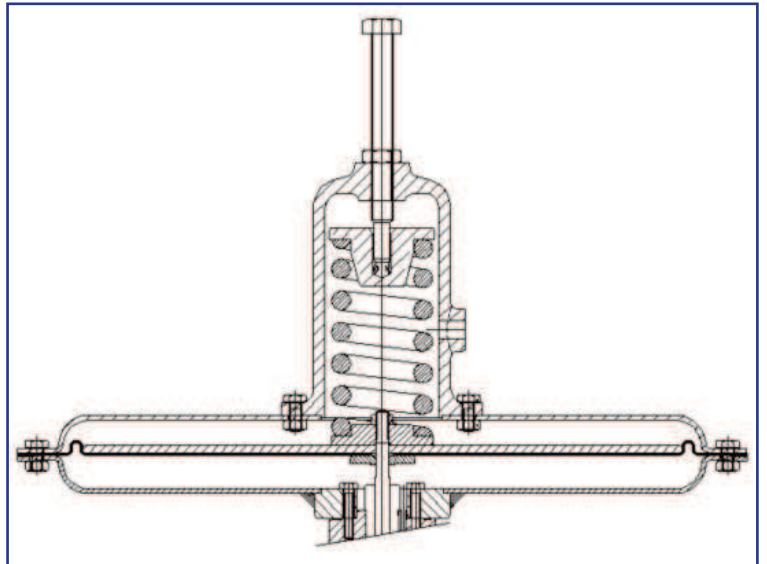

UBAN actuators:

The above drawings show all our available actuators, which are perfectly interchangeable the one with the others according to the desired pressure regulation (please refer also to Tab. 4 on page 3). The table below shows the actuators dimensions.

About Carraro

Carraro Srl is a private independent company, operative since 1924 in the field of industrial valves. The firm produces and commercializes worldwide a broad range of industrial pressure regulators, desuperheaters and safety valves for fluids such as steam, process gases and liquids.

The flexible organization of Carraro allows a great customization of the products and the production of “taylor made” constructions. Most of the Carraro’s product range can be realized also in “exotic” materials such as e.g. duplex, superduplex, monel, hastelloy, aluminum bronze and others. Supported by a global network of sales offices, representatives and distributors, Carraro offers a wide range of solutions for the Oil&Gas, the Power industry and all other diversified industrial applications.

Carraro: product range

UB Regulators: direct-operated pressure regulators with compact design

Maxomatic Series: multifunction pilot-operated regulators for liquids

MM-BPM series: direct-operated, spring pressure regulators

AT series: direct-operated temperature regulators

M51 series: direct-operated, weight and lever pressure regulators

CS series: safety valves for vapours, gas, liquids

CSV series: safety valves for steam and gases

VRE series: electrically operated control valves

MCP - ACP series: pneumatically operated control valves

AIRMATIC series: electropneumatic safety valves

DSH series: desuperheaters

Approvals and certifications

UNI EN ISO 9001: 2008	✓
UNI EN ISO 14001: 2004	✓
97 / 23 / CE (PED)	✓
94 / 09 / CE (ATEX)	✓
RINA	✓
GOST R+RTN	✓
CRN Canada	✓

Cooperations with notified bodies

LLOYD’s REGISTER	✓
ABS	✓
BV	✓
DNV	✓

How to contact us

VIA ENRICO FERMI, 22
20090 SEGRATE (MI) ITALY
TEL. +39 02 269912.1
FAX +39 02 26922452

info@carrarovalvole.it
sales@carrarovalvole.it
technicaldep@carrarovalvole.it
customerservice@carrarovalvole.it



Vallenvägen 5, 444 60 Stora Høga · 0303 - 79 81 50
info@corona-control.se · www.corona-control.se

 **CARRARO**[®]
www.carrarovalvole.it

